

Organisation

Amperes has entered its 18th years of operation since its incorporation in the year 1999 / 2000. It started humbly in Puchong, outskirts of Kuala Lumpur and has since grown in sync with the growth of the township itself. From a small bench, we grew with passion, pursuing and focusing on vision and we had expanded our production floor areas by many folds.



Management & Processes

At management and operation, Amperes adheres to the strict requirements of ISO 9001 : 2015 standards. This is to ensure that the processes in manufacturing are carried out in systematic manner, responding the feedback and in overall, our valued clients receive the products and services at optimum quality.

As a dynamic company, Amperes never cease to seek new ways in manufacturing methods, minimizing human errors by mechanizing and automating processes to ensure our products are able to operate for years without worry.



Products

We invested substantially and continuously in Research and Development, keeping abreast with latest technology to be a key player in Paging, BGM and EVAC systems. From its first product ; ZS601 zone selector and other customised panels, the creations of new models has multiplied to over 150 types. IOT has taken its role in Public Address System and therefore, more products with IT related features had been produced and being updated to accommodate the ever increasing sophisticated specifications.

Reaching Out

We invested substantially and continuously in Research and Development, keeping abreast with latest technology to be a key player in Paging, BGM and EVAC systems. From its first product ; ZS601 zone selector and other customised panels, the creations of new models has multiplied to over 150 types. IOT has taken its role in Public Address System and therefore, more products with IT related features had been produced and being updated to accommodate the ever increasing sophisticated specifications.



Our Mission

And no matter how complex the products or systems to be integrated, Amperes has one simple philosophy - " to provide economical yet contemporary products and solutions " .

Stay with us, we are ready to provide our solutions for few more decades to come. We listen and react, seek and apply the shared knowledge to achieve a brand name of

" Precision Design, Absolute Confidence "



A Member Of :

Fed of Malaysia Manufacturer (FMM)
Malaysia External Trade Development Corporation (MATRADE)
The Electrical and Electronics Association of Malaysia (TEEAM)



1 IP BASED PA SOLUTION

Introduction	IP Based System	05
iPX5101	Ethernet Paging Server	06
iPX5200	Ethernet Music Server	07
iEP1200	Ethernet Emergency Paging Panel	08
iPA2000	Ethernet Upcoming Products	09
iPX5151	Ethernet Paging Client	10
iPX5155	Ethernet BGM / Paging Client	10
iPX5300	Ethernet Music Client	10
iPX5500	Ethernet Comm. Box	10
	Sample Schematic	11

2 SOFTWARE BASED PA SYSTEM

PMX II	Standard Music Server Software	12
PMX II LAN	LAN Based Music Server w. Monitoring	13

3 MATRIX

MxP2288	12 x 8 Matrix Paging Controller	14
	Matrix System Components	16

4 PAGING MICROPHONE

PD1900	Touch Screen Paging Microphone	17
PD1240	Digital Paging Microphone (Soft Touch)	18
PD1280	24 Zone Digital Paging Microphone (Soft Touch)	18
PD2400	24 Zone Digital Paging Microphone	19
PD2800	Digital Paging Microphone	19
PD1160	8/16 Zone Digital Paging Microphone	19
PM1000	Analogue Desktop Paging Microphone	20
PM1060	6 Ch Analogue Desktop Paging Microphone	20
PM1120	12 Ch Analogue Desktop Paging Microphone	20
EP1200	Emergency Paging Microphone Panel	21

5 INPUTS

CM1400	Chime & Siren Tone Generator	22
CD1001	DVD/CD/MP3/AM-FM Tuner	23
MP1020	2 Ch Media Player	23
MR1301	Message Recorder / Player	24
PT1801	Weekly Programmable Timer	25
FI6000	Fire Alarm Interface / Controller	26

6 MIXERS

DA2208	2 Input 8 Output Signal Distribution Amplifier	28
MX2222	Pre-Amplifier Mixer	29

7 POWER AMPLIFIERS

PA300S	10 / 20 / 30W Mini Amplifiers	30
PA2000S	120 / 240 / 360 / 480 / 600W Power Amplifiers	31
QP2000S	125 / 250 / 375 / 500W Power Amplifiers with AFS	32
DP2000S	Multichannel Power Amplifier	33
MA2000S	60 / 120W Mixer Amplifier with Zone Selection	34
MC2000S	60 / 120W Basic Mixer Amplifiers	35

8 AMP. CHANGEOVER & MONITORING

AC3801	8 Duty / 1 Standby Manual Changeover Panel	38
AX3800	8 Duty / 1 Standby Auto Standby Amplifier Fault Changeover	39
LS4808	8 Channel Speaker Line Surveillance	40
LS4816	16 Channel Speaker Line Surveillance	40
AM4120	12 Channel Amplifier Monitor Panel	41
AS4000	Amplifier Surveillance Module	41

9 SELECTOR & DATA DECODER

ZS5062	6 Ch Speaker Zone Selector	42
ZS5122	12 Ch Speaker Zone Selector	42
ZS5601	6 Ch Speaker Zone Selector	43
ZS5121	12 Ch Speaker Zone Selector	43
ZS5602	6 Ch Uninterrupted Paging Speaker Zone Selector	44
SS6401	Source Selector	44
TD6080	8 Ch Decoder / Zone Selector	45
TD6240	24 Ch Data Decoder	45

10 POWER SUPPLIES & DISTRIBUTION

BC9740	24V DC Automatic Battery Charger	46
SQ9815	Sequential Power Switcher	47
PS9400	Regulated 24V DC Power Supply	47

11 VOLUME CONTROLLER / PATCH

VR7600S	6 Zone Rack Mounted Volume Controllers	48
AV7200	Auto Volume Controller	48
VC7000S	5 / 10 / 30 / 50 / 100 / 150W Volume Controllers	49
VC8000S	5 / 10 / 30 / 50 / 100W Volume Controllers	49
VP7501	Speaker Patch Panel	50
VP7810	100V - 8 Ohm Speaker Patch Panel	50

12 SPEAKERS

CS Series	2" / 5" / 6" - 6W 100V Line Ceiling Speaker	51
CS Series	4" / 5" / 6" - 6W 100V Line Ceiling Speaker	52
CS620/840	Co-axial Ceiling Speaker	53
BS / DV410	Surface Mount Speakers	54
FS Series	Full Range Speakers	55
CL / CH Series	Column Speakers	56
PS / SG	Pendant Ball / Ground Speakers	57
SP Series	Projection Speakers	58
HS Speaker	Horn Speaker	59

13 OTHERS

Accessories	Complimentary product	60
Technical	Product Selection Guide	04
	Technical Terms	27
	SPL and dB Loss in Cabling	36
	Speaker Distribution	37
	Calculating Back Up Battery	61
	IP Rating	62
	VAS Code of Practice	63

Amperes has variance of products to choose from practically for almost all applications, be it a simple mixer amp or more complex audio distributions with multiple building blocks.

The table below provides a quick equipment selection guide. As quantity or product type may vary for different applications, such as size, budget or customer's requirement, you are welcomed to contact us for free consultation.

No	MODEL	Basic	Analogue	Digital	Matrix	IP Based
1	iPX5000 Series			✓	✓	✓
2	PM1000 Series	✓	✓	✓		
3	PD2000 Series / PD1160			✓	✓	✓
4	PD1240 / PD1280 / PD1900			✓	✓	✓
5	EP1200		✓	✓	✓	✓
6	CM1400	✓	✓	✓	✓	✓
7	CD1001 / MP1020	✓	✓	✓	✓	✓
8	MR1301		✓	✓	✓	✓
9	TD6240 / TD6080			✓	✓	✓
10	PT1801		✓	✓	✓	✓
11	FI6000		✓	✓	✓	✓
15	PMX Systems		✓	✓	✓	✓
16	MxP2288				✓	✓
17	RP1104				✓	✓
18	MX2222		✓	✓	✓	✓
19	DA2208		✓	✓	✓	✓
20	QP2000 Series		✓	✓	✓	✓
21	PA2000 / DP2000 Series	✓	✓	✓	✓	✓
22	MA / MC2000	✓	✓			✓
23	PA310 / 320 / 330	✓	✓	✓	✓	✓
24	AX3800 / AC3801		✓	✓	✓	✓
25	AM4120		✓	✓	✓	✓
26	LS4800 Series		✓	✓	✓	✓
27	ZS5601 / 5121 / 5602 / 5122	✓	✓	✓	✓	✓
28	SS6401	✓	✓	✓	✓	✓
29	SQ9815	✓	✓	✓	✓	✓
30	BC9740	✓	✓	✓	✓	✓
31	PS9400	✓	✓	✓	✓	✓
32	VR7600		✓	✓	✓	✓
33	AV7200		✓	✓	✓	✓
34	VC7000 / 8000	✓	✓	✓	✓	✓
35	VP7501 / 7810	✓	✓	✓	✓	✓

- Basic setup : restaurants, meeting rooms, lecture halls, mobile PA
- Analogue : small buildings, offices, entertainment outlets, schools
- Digital : medium size or high rise buildings exceeding 12 zones, hypermarkets, university / college campus
- Matrix : Bungalows, club houses, entertainment centre, offices which require flexible music selection
- IP System : Large scale installations with multiple blocks, remote installations, transportation hub or stations, universities, etc

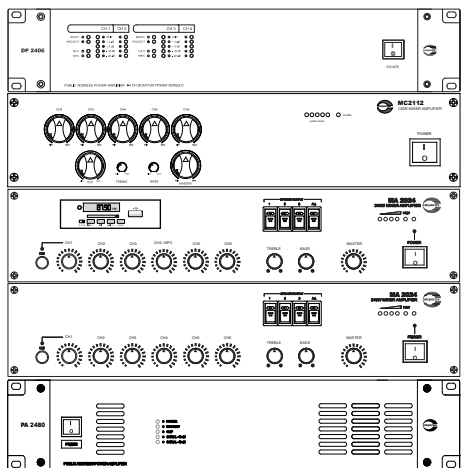
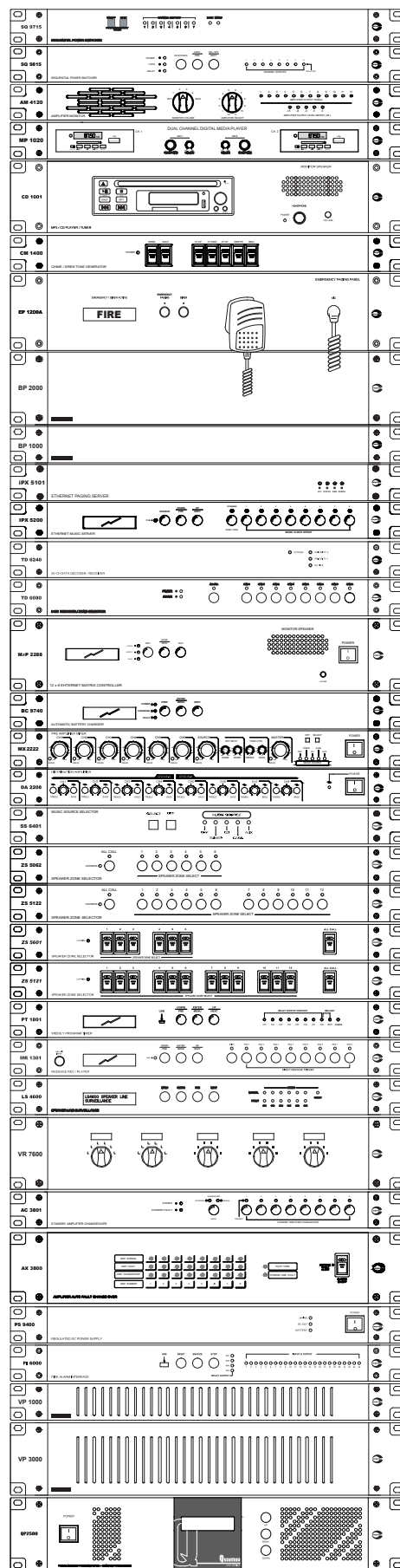

Product outline drawings can be downloaded from our website



Introduction

iPX5101 is the network controller of connected IP devices to the system. All traffics and communications are regulated and monitored by it such as priority access of network clients, logging details, etc. In default, Amperes iPX System operates on Multicast mode but some device can work on Unicast if required. (Please refer to iPX5155).

Initial settings of overall system starts from iPX5101, accessed via its friendly browser. Only a single controller is required for overall system. With constant updates available for more and more upcoming features, iPX5101 shall never be obsolete, but it just get better.

Rear View:



Packing information

Qty per carton : 1 unit
W x H x D : 552 x 93 x 294 mm
Weight : 2.9 kg

Technical Specifications

Power requirement :	
Voltage	18 ~ 24V DC (Normal DC 24V)
Current	350 mA

Connectivity	
- LAN interface	RJ-45, 100Mb/s
- Common protocols	TCP/IP, UDP, IGMP, HTTP
- Priority protocols	UDMP, ADP

Client connection	255 Max
User interface	(Web Browser) IE V8+, Firefox V22+, Google Chrome V25+, RS485
Firmware upgrade	Via Web Browser

Operating condition :	
Temperature	-20°C ~ 80°C
Humidity	80%

Case :	
Dimension	482 x 44 x 180 mm
Weight	1.9 kg

Application Schematic

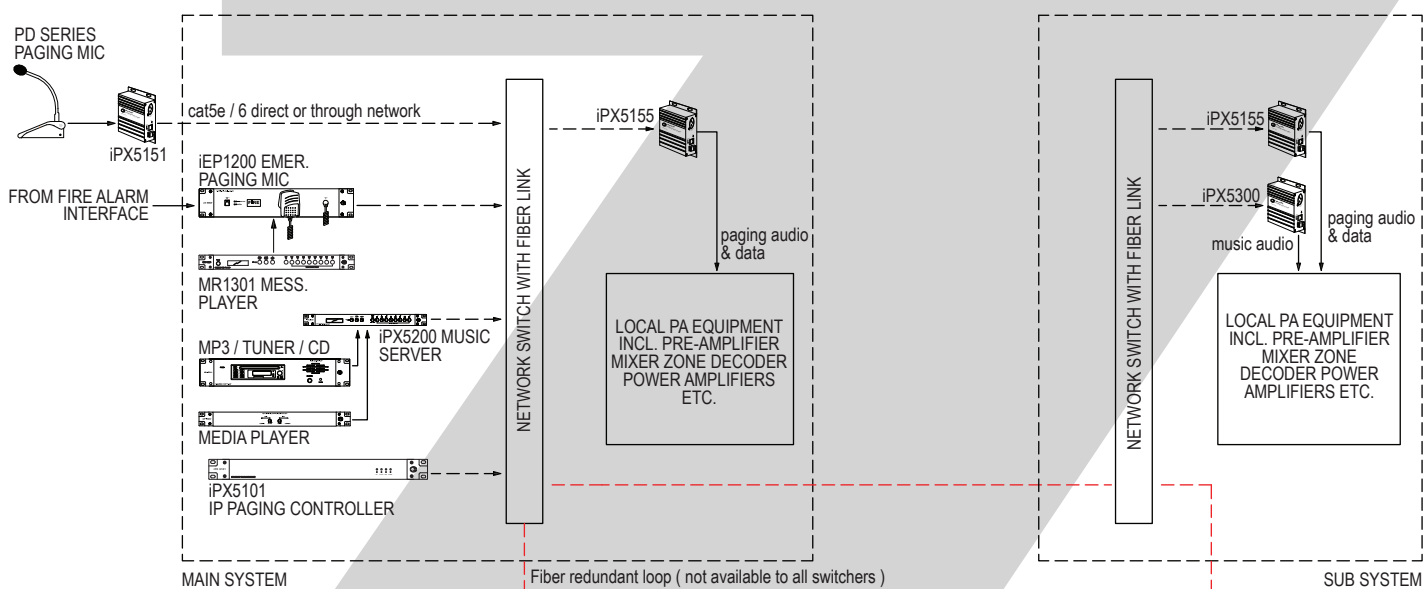



Introduction

iEP1200 is an extension of the conventional EP1200 Emergency Panel which is now LAN ready. It is an essential tool for firemen to access directly to EVAC system with highest priority. All other paging in progress, music streaming would be directly cut off upon activation of the unit.

It has an added feature as compared with the conventional type, i.e. it can be programmed as local system's highest priority paging device (for distributed system), or as a global highest priority. Although it is essentially an IP-based device, other analogue ports are available such as message player input, emergency dry contact and aux line audio output. Setup shall be done via web browser.

Rear View:

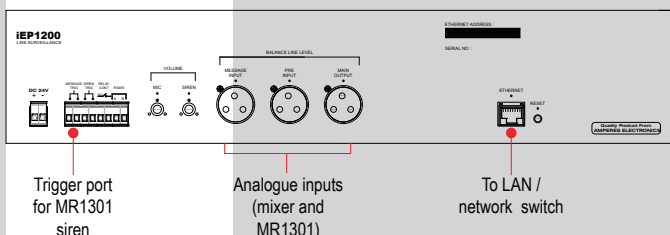

Features

- Simple initial setting via web browser
- Local or Global high priority setting
- Built-in siren tone generator with dual mode activation
- Visual FIRE indicator
- Dry contact for unit's activation
- Aux RS485 data comm port
- Volume controls for siren, mic and message sources

Technical Specifications

Power requirement	24V DC
Power consumption	5W
Microphone	
Siren frequency	Continuous at 8 KHz
Inputs	Balanced line out (1.2V)
Priority sequence	Paging mic - siren - message - pre amp in
Indicators	Front test switch / remote contact
Data Connectivity	RJ45 ; 100 Mbps
User interface	http ; IE Ver 8 and above, Google Chrome, RS485, Firefox V22+
Protocols	TCP/IP, UDP, IGMP, Http
Dimension (WxHxD)	482 x 88 x 180
Weight	3.4kg

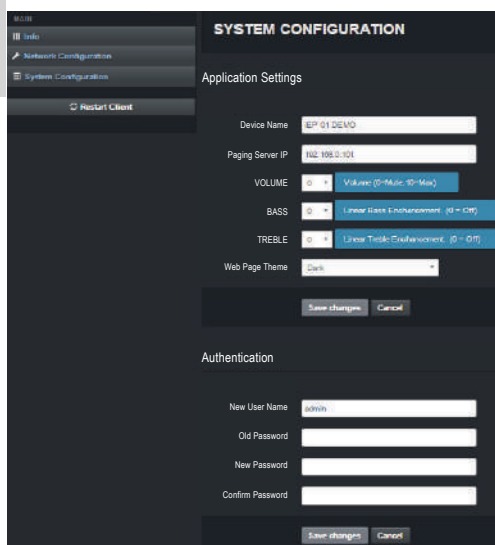

Web Interface

Introduction

With the growing momentum of IT in EVAC / BGM systems, thus called IP Based PA System, Amperes has several upcoming line ups to offer. The following products are currently being developed and shall be rolled out soon.

iPD1902

Ethernet Touch Screen Paging Mic

It is an extended version of PD1900 for IP Paging System setup, comes with 7" capacitive type touch panel. It is suitable for medium to large scale installations and has the convenience of mobility to connect to central system within the LAN.

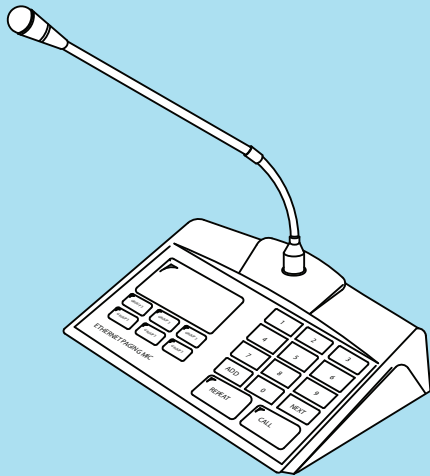

IEP1202

Ethernet Emergency Paging Console

A remote Emergency Paging station, suitable when it is to be installed away from the rack, such as Command Centre. It shall come with programmable zone grouping buttons and siren activation switch. It has the highest priority setting among all other audio sources.

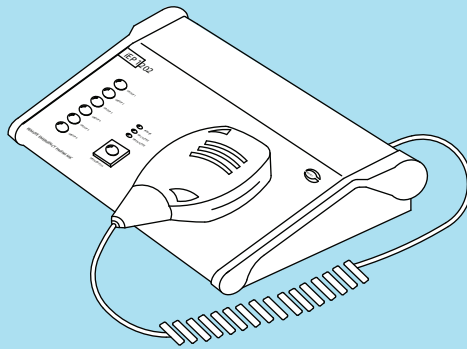

iPA5060

Ethernet Amplifier Terminal

Compact remote IP amplifier terminal available in 60W 100V line, applicable for decentralised system. Suitable for installation at risers, kiosks such as park entrance / ticketing booth, poles etc. It has local mic input for localised paging.

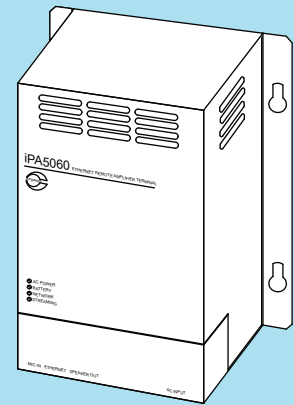

iPA5240

iPA5480

Ethernet Power Amplifier

Rack mounted Ethernet based amplifiers suitable for installation at main rack or at remote sub racks. It has 4 controllable output zones, thus eliminating the usage of zone decoder / selectors. It shall be available in 240 and 480W 100v line variants.

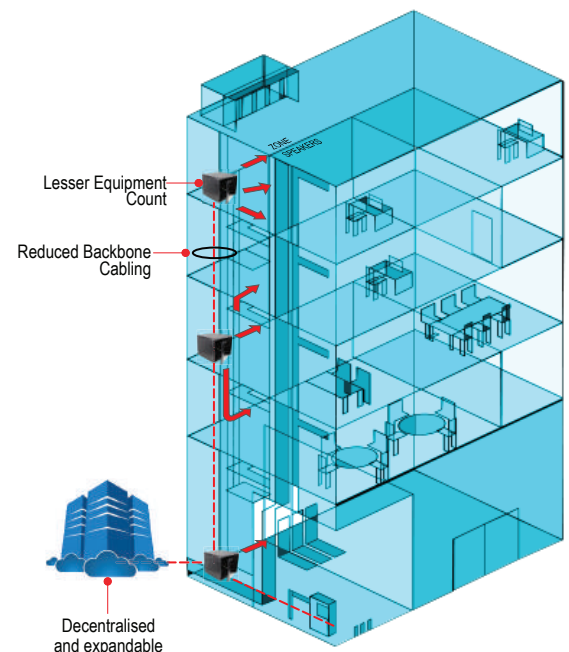
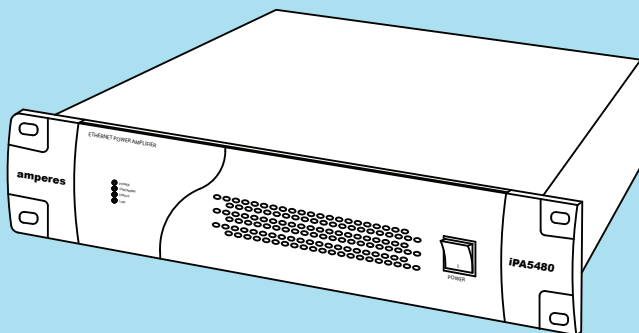

NOTE :
Preliminary information, subjected to charges upon availability.



iPX5151
Ethernet Paging Client

iPX5151 is the Ethernet Paging Client which receives and transmits paging audio and RS485 data from digital paging microphone, which is then connected to network switch.

Audio conversion is centered at voice frequency for optimum paging quality.



iPX5155
Ethernet BGM / Paging Client

iPX5155 is a combination of Paging and Music streaming device in a box, which is intended to reduce the equipment count for distributed paging setup in a LAN environment.

It has BGM muting feature upon receiving paging broadcast to the unit and can be configured as Unicast or Multicast.



iPX5300
Ethernet Music Client

iPX5300, Ethernet Music Client is used to receive audio streaming from central rack either from iPX5200 Ethernet Music Server or via PMX II LAN. Quality sound can be expected as it plays MP3 audio at up to 320 kbps.



iPX5500
IP Communication Box

iPX5500 is the communication interface for equipment with RS485 outputs and remote PC, enabling remote monitoring and controls via Amperes PMX II LAN software. It converts RS485 data received from equipment into IP and shall be received by remote PC in the LAN environment. Likewise for remote controlling, user would be able to perform setting or changing parameters via the software modules available in PMX II LAN.

Packing information

Qty per carton : 1 unit
W x H x D : 168 x 102 x 190 mm
Weight :
iPX5151 / iPX5155 : 1 kg (include adaptor)
iPX5300 / iPX5500 : 1.2 kg (include adaptor)

Technical Specifications

	iPX5151	iPX5155	iPX5300	iPX5500
Power requirement : Voltage Current	12 ~ 24V DC (Normal DC 24V) <100 mA			
Connectivity - LAN interface - Common protocols - Priority protocols	RJ-45, 100Mb/s TCP/IP, UDP, IGMP, HTTP UDMP, ADP			
Broadcast mode	Unicast / Multicast			Multicast
Audio - Analogue in/out (peak-to-peak) - Input load resistance - Input load Capacitance - Total harmonic distortion (THD) - Audio conversion - S/N ratio (full scale signal) - Digital format	1.25Vrms 30 Ohm 100 pF 0.1% 83 dB IMA ADPCM / MP3 (CBR / 320 kbps max) / WAV			Not applicable
User interface	(Web Browser) IE V8+, Firefox V22+, Google Chrome V25+, RS485			
Firmware upgrade	Via Web Browser			
Operating condition : Temperature Humidity	-20°C ~ 80°C 0 - 70%			
Case : Dimension (WxHxD)	100 x 147 x 40 mm			
Weight	300 g			320 g

The diagram illustrates the different configurations possible for various end applications or setups.

MAIN CONTROL ROOM

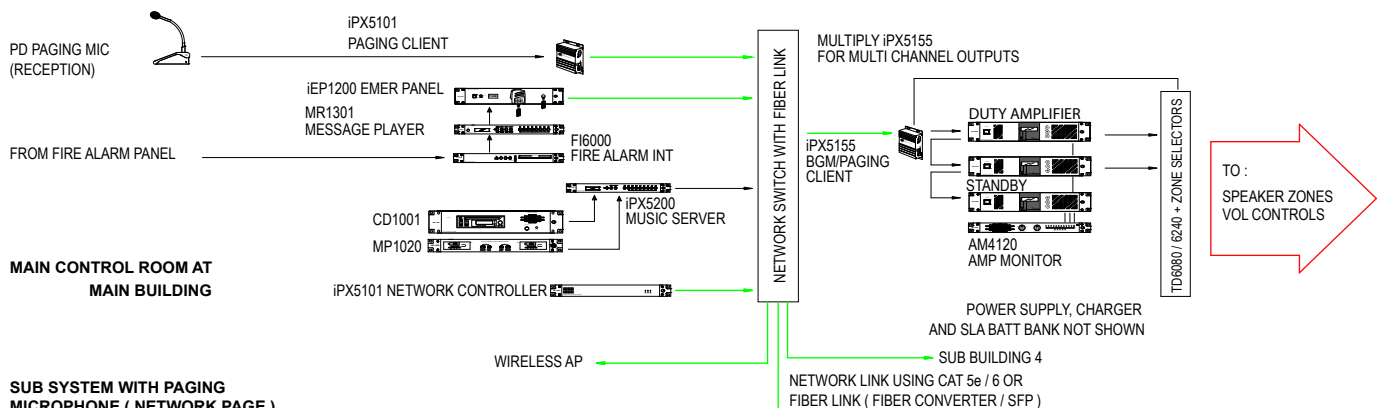

SUB SYSTEM WITH PAGING MICROPHONE (NETWORK PAGE)

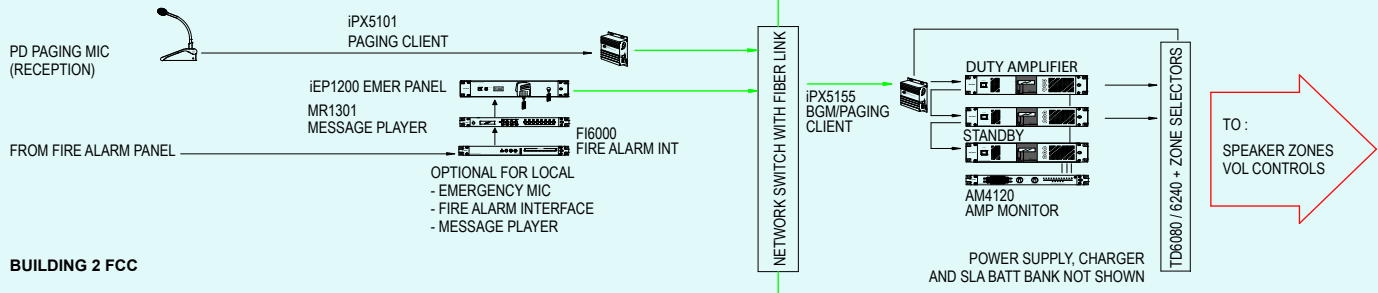

SUB SYSTEM WITHOUT PAGING MIC

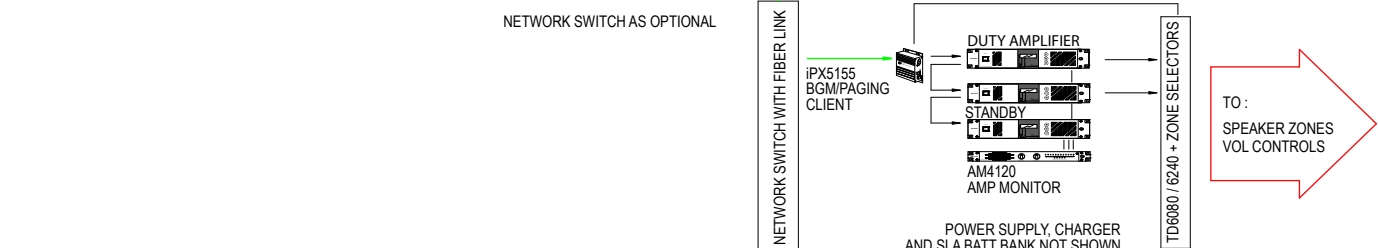

BUILDING 3 FCC

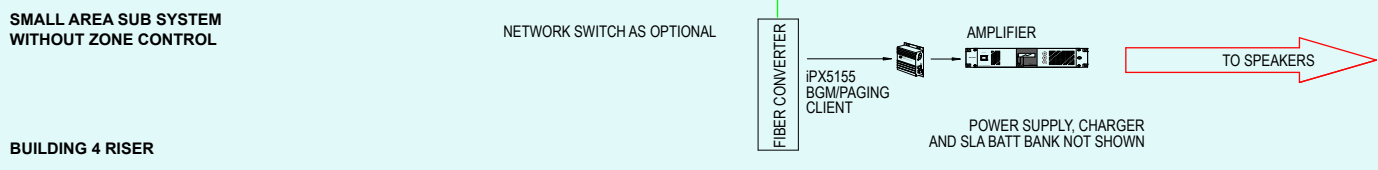

ISOLATED SUB SYSTEM WITH WIRELESS CONNECTIVITY TO THE LAN

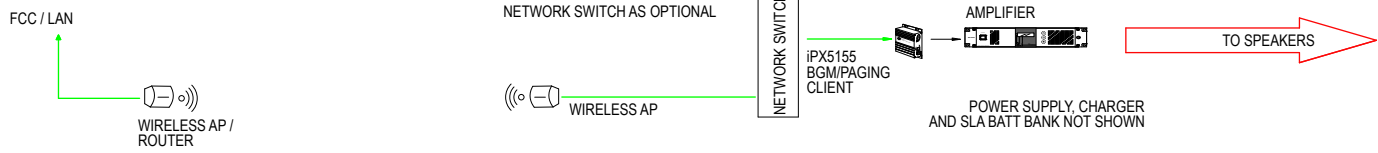

EXTERNAL POLE

NOTE :

- Application using PMX LAN not shown.
- Other equipment such as speaker line surveillance, changeover panell, volume controls, etc not shown and to be incorporate if required.

Other possible configurations:

- Uninterrupted paging
- Localised paging and BGM system with link to main network for emergency paging.
- Localised paging terminal such as kiosk or sentry.

Introduction

PMX II is software that consists of virtual hardware components such as Music Player, Music Storage, Programmable Timer, Message Player and Paging Station. It is a standalone version and runs on PC with operating system of Windows 8 and above. With a converter as dongle, the audio and control outputs from PC shall be fed to conventional PA rack, enriching the entire installation to a more sophisticated setup.

The user interface had been made to be user friendly, enabling smoother setup and viewing. The system shall be able to integrate freely with existing equipment such as zone decoders, paging microphones with different priority level and emergency paging panel which the activities would be monitored in the screen.

Among suitable installations includes offices, transportation stations, malls, hotels, schools, etc.

Features

- Media playback module to feed BGM audio to PA system for MP3, WAV or other supported audio files by Windows Media Player.
- Media Library to store unlimited songs, messages, tones or chimes in HDD for playback
- Weekly programmable timer allows repetitive playback of tones or chimes
- Calendar scheduling to playback songs such as birthday songs
- Controls up to 256 zones which is linked to external zone selector such as ZS5121 via TD6240
- Zone configuration allows naming each zone to specific name and assignable as Normal or Emergency zone.
- Paging or messaging to zone or groups of zones, with priority overriding for Emergency Call

Application Schematic

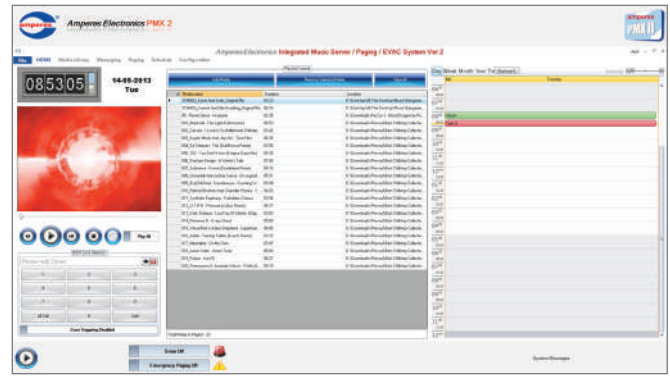
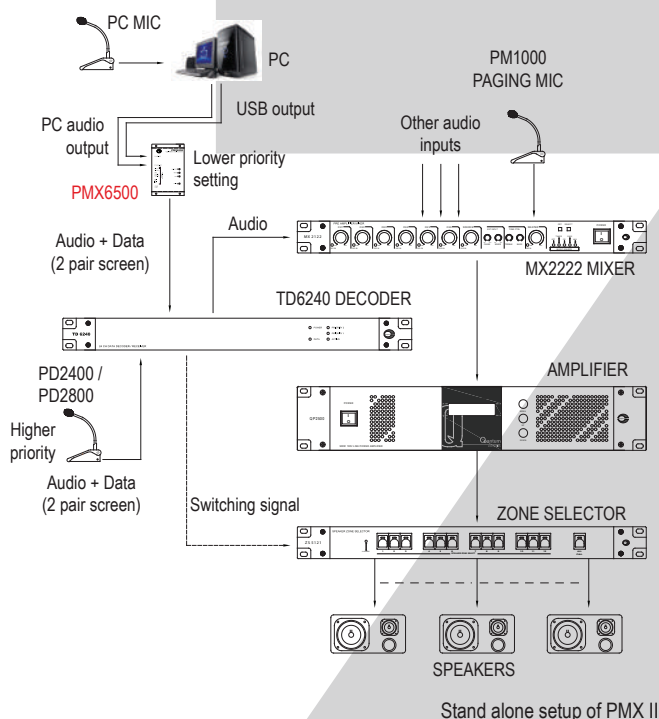

Main Page

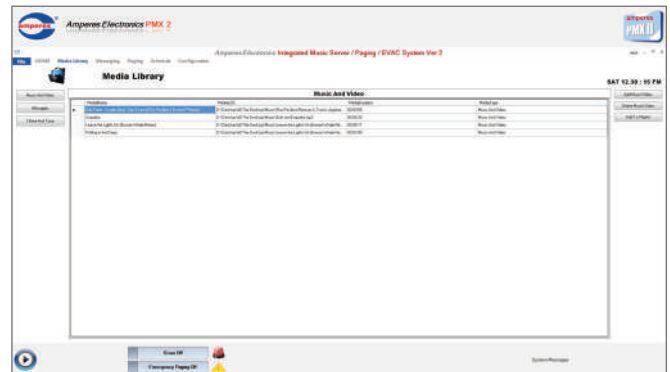

Media Library

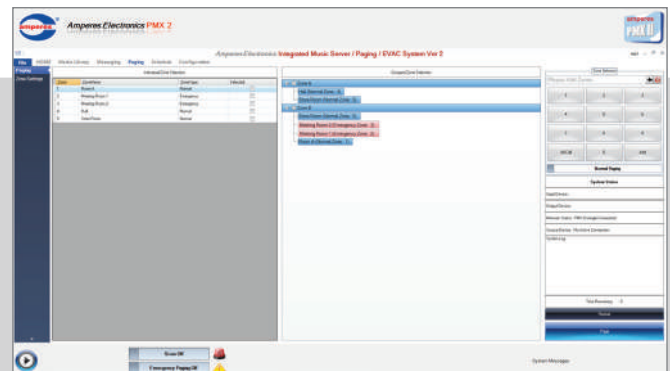

PC Paging Interface

External Device Status

System Status	
Input Device :	Microphone Array (Sound Blaster)
Output Device :	Speakers (Sound Blaster Recon3D)
Network Status :	All Call
Source Device :	PD2800
System Log	
Time Remaining : 0	
<input type="button" value="Repeat"/>	
<input type="button" value="Page"/>	
System Messages	

PACKING INFO:



- Software CD
 - PMX II stand alone only:-
 - PMX6500 USB to RS485 converter
- W x H x D : 190 x 168 x 102 mm
Weight : 1.05 kg



PMX II LAN version has all the features of PMX II standalone but it runs on LAN environment and would be able to work with other Amperes IP products such as Music Client, Communication Box and soon the IP MatriMix. In addition, it contains the extension modules of equipment User Interface, such as QP2000, FI6000, AX3800 and other upcoming models which would be available for free updates.

With the extension modules, user shall be able to control and monitor status of equipment from multiple locations within the local area network. Among them, controlling the volume control of power amplifiers, fault changeover notifications, emergency paging activation alert and so forth. Application of these extensions would require the usage of iPX5500 communication box, which receives RS485 data from equipment and send to the PMX software and vice versa.

With the advent of IP technology in PA systems, PMX LAN would be the essential component sought after and it is a cost efficient way to an advanced paging system.

Application Schematic

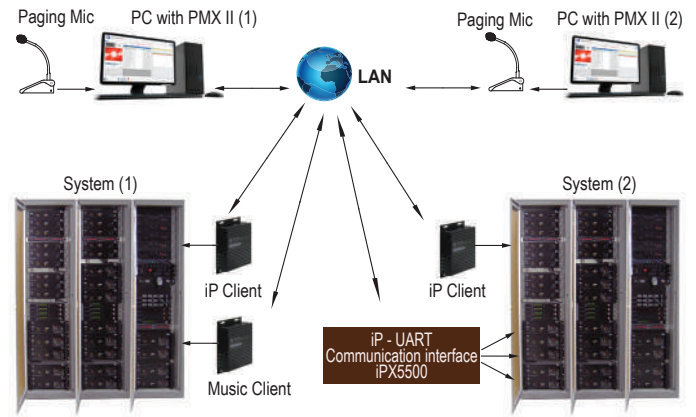

Components in PMX LAN

Paging and message
Click to access paging control panel

Client Info :
Showing music clients connected to system

Playback Controls :
Control buttons for music playback

Emergency Paging Status :
Indications for emergency paging in progress

Playlist :
List of messages or songs for playback

Combox Manager:
Interfacing to external equipment for monitoring and control

Scheduling
Events / messages scheduled for playback

System message:
Status of PMX communication

PMX IP Info :
Information of PMX IP address

30/6/2015	PC IP	0
Tuesday	Clients Online	0
	Channels Online	0 of 0

HARDWARE REQUIREMENT :

PC with 4GB RAM (higher RAM required for simultaneous multichannel music playback) with Windows 8 and above operating system. Intel i3 and above processor or equivalent recommended.

MxP2288

12 x 8 Matrix Paging Controller

Introduction

MxP2288 succeeded its predecessor MxP2188 which had been running for over a decade long. Various features are introduced to fulfill the sophisticated demands of today's PA installation. Apart from the value added features, operating and installation works has been greatly simplified. It is undeniable an advanced and user friendly product ever produced by Amperes.

Be it a standalone installation or a networked (LAN) setup, MxP2288 shall outshine others in its class, which we learnt and applied all feedbacks, making it a truly outstanding equipment worth invested in. It is suitable for both commercial and residential application.



12 X 8 MATRIX CONFIGURATION

8 mic / line audio sources, dedicated EP1200 Emergency Paging Panel, MR1301 Voice Message Recorder / Player, PD Series Paging Console and network audio streaming through iPX5200.

POWERFUL PROCESSOR

Built with powerful ARM 32 bit processor, MxP2288 shall perform various tasks smoothly and would be able to cater for future upgrades in features that would be available from time to time.

ZONE EXPANSION IN CASCADE MODE

Output zones can be expanded up to 96 zones making the overall configurations as 12 x 96. Interlinks between stacked units had been made easy with Link Cables provided, thus making overall interconnections look neat and pleasing. As each audio connection is buffered, audio distributor shall no longer be required, thus saving component count in the installation.

FLEXIBLE AUDIO SOURCE

Combo jacks are provided for inputs section which accept either XLR or 1/4" stereo phone jacks. Audio source (Line or Mic level) shall not be an issue as MxP2288 accepts both levels and would provide balanced line levels at its outputs.

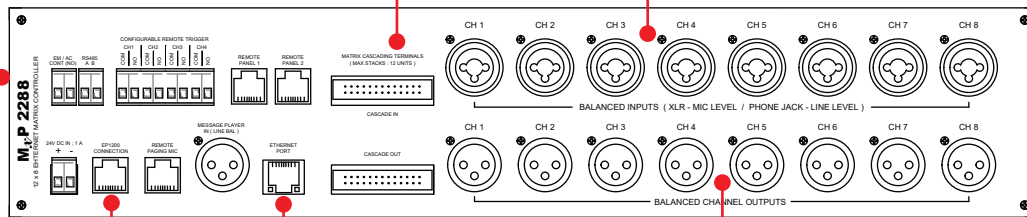

FAIL SAFE OPERATION

With EP1200 connected, overall operation would operate seamlessly even if the matrix unit is digitally down or in off mode. This emergency paging bypass mode is essential to ensure important paging shall continue uninterrupted in critical moments.

OUTPUTS WITH INDIVIDUAL VBT

Each output has its own volume, bass and treble (VBT) setup, thus enabling fine tuning the audio of each zone.

PRIORITISED AUDIO ROUTING

While the main function of MxP2288 is offering flexible audio routing, it is also designed to perform prioritised audio broadcast, which Emergency Paging would have highest priority, followed by message broadcast from MR1301 and normal paging.

NETWORK (LAN) READY

With its LAN ready feature, it can be accessed directly through web browser for configuration, channel routing and also channel VBT controls, either from a PC or via Tablet. Anywhere within the LAN (including WIFI access), the controller is always within the command of the user.

Technical Specifications

Configuration	12 x 8 matrix controller
Power source	24V DC ; 1A
Inputs channels	8 mic / line level balanced signal via combo jacks 1 x emergency mic panel (EP1200) 1 x message player (MR1301) 1 x paging mic (PD series) 1 x LAN music streaming via iPX5200
Input connections	Combo jack; Mic (XLR), phone (1/4" stereo phone jack)
Input impedance	Mic: 600 Ohm Line: 10K Ohm balanced
Input sensitivity	800mVrms (line level) and 350mVrms (mic level)
Frequency response	150Hz - 17 KHz (+/-3 dB at 1 KHz) with low cut
Total harmonic distortion (THD)	0.10%
LAN audio streaming	16 - 48 KHz PCM (Browser Streaming) 128Kb/s CBR MP3 (PMX / iPX Music Streaming)
Paging audio streaming	IMA ADPCM (16 KHz)
Digital format	PCM / ADPCM / OGG / MP3 / WMA / WAV
Audio output	8 x balanced line output via XLR jacks Cascade link via flat cable
Tone / volume controls	Bass: +/-14 dB cut and boost (2 dB step) Treble: +/-14 dB cut and boost (2dB step) Volume: 0 dB to - 78.75 dB (1.25 dB / step)
Audio gain (max)	+4 dB
Output audio monitoring	Via front 3W speaker

Communication control	RS485; 19.2 Kbps
User interface	Direct web interface via LAN for PC and WIFI for TAB and Phone
Remote controls	Via PC / Tablet / Smartphone
Unit cascade control	12 units / 96 output channels
Trigger port	Message / Emergency Paging (programmable)
Priority controls	BGM (Local source, iPX) Paging Message Emergency Paging (highest priority)
Fail safe feature	Emergency paging bypass
E/M override contact	3A dry contact
Dimensions (WxHxD)	482 x 88 x 180 mm
Weight	3.3 Kg

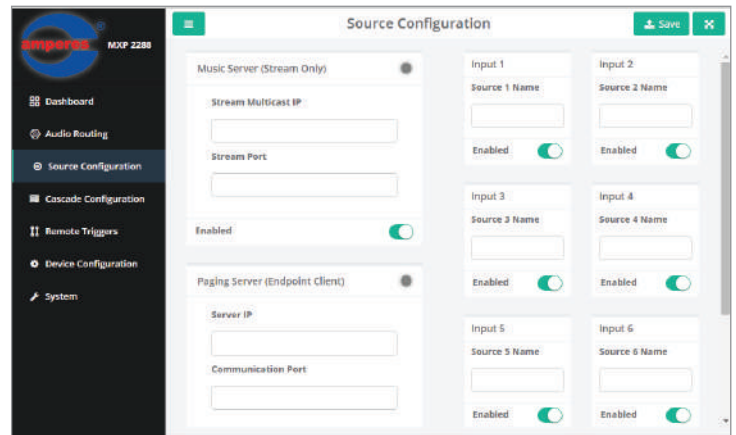

Browser Interface

Application Schematic

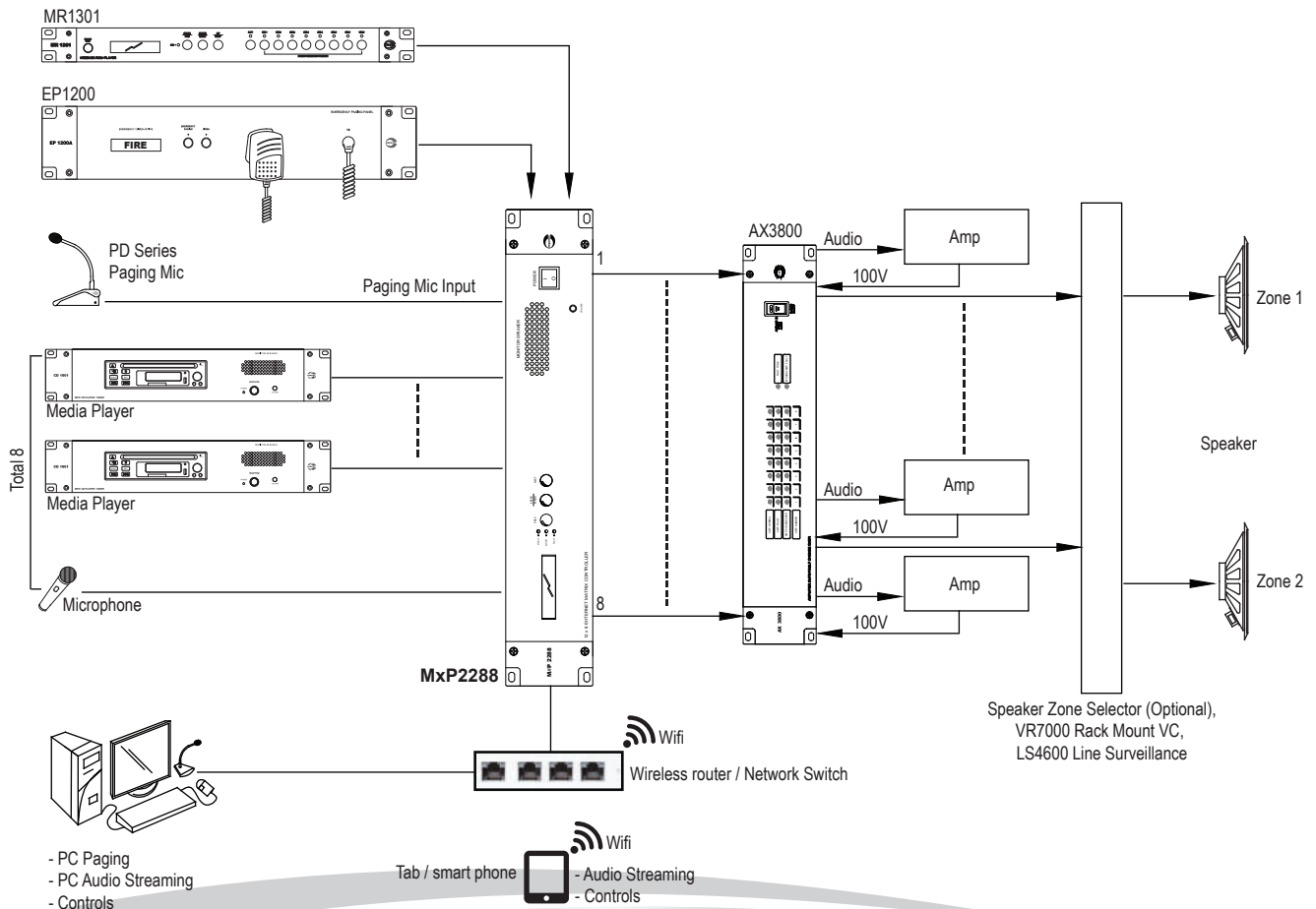



NEW

Preliminary Info

RP1104 - Remote Zone Control Panel

A remote zone controller with sensor touch buttons which allows the user to select input music source, volume and tones. It shall be installed at remote location at individual zone and connected to the MxP2288 controller via Cat5e / 6 UTP cable. Each controller shall run individually to each input port of the respective zone.



PD1160 - 8/16 Zone Remote Paging Microphone

It is a simple and dedicated paging microphone for connection to MxP2288 MatriMix system with 8 / 16 zones call station.

- Multipoint paging with EX1102 mic extender
- Direct connection to MxP2288 controller.

Power source	24V DC via MxP2288
Power consumption	100 mA
LCD panel	3.5" resistive touch screen
Communication	RS485 ; 19.2 Kbps
Controls	Volume / BGM source / tone controls
Cabling	Cat 5e / 6
Distance	Up to 500m
Dimensions (WxH)	86 x 86 mm
Color	White
Weight	100 g

Power requirement	24V DC via MxP2288 / TD6080
Power consumption	200 mA
Zone selection	8 / 16 zone keys with ALL CALL
Data connection	RJ45
Operating distance (data)	300 m
Audio distance	300 m
Indicators	Power, source, volume, busy
Dimensions (WxHxD)	150 x 186 x 62 mm (body only)
Weight	1.0 kg



EX1103 - Paging Mic Extender

When multipoint paging is required, EX1103 shall be used, with each PD1160 connected in series in a single circuit. The mic nearest to the Matrix controller shall have priority over its precedence.

TOUCH SCREEN PAGING MICROPHONE

PD1900

NEW

Introducing a new tool in a new age of paging, ie PD1900 touch screen paging microphone. Its features a 7" capacitive type touch screen panel with 800x480 pixel resolution, providing contemporary outlook with ease of operation.

It is compatible with all zone decoders, IP paging clients and MxP2288 matrix controllers, with built in chime, volume controls and other hosts of features that would be made available from time to time. Integrate it to your PA system, and definitely it would bring up a class above from the rest.

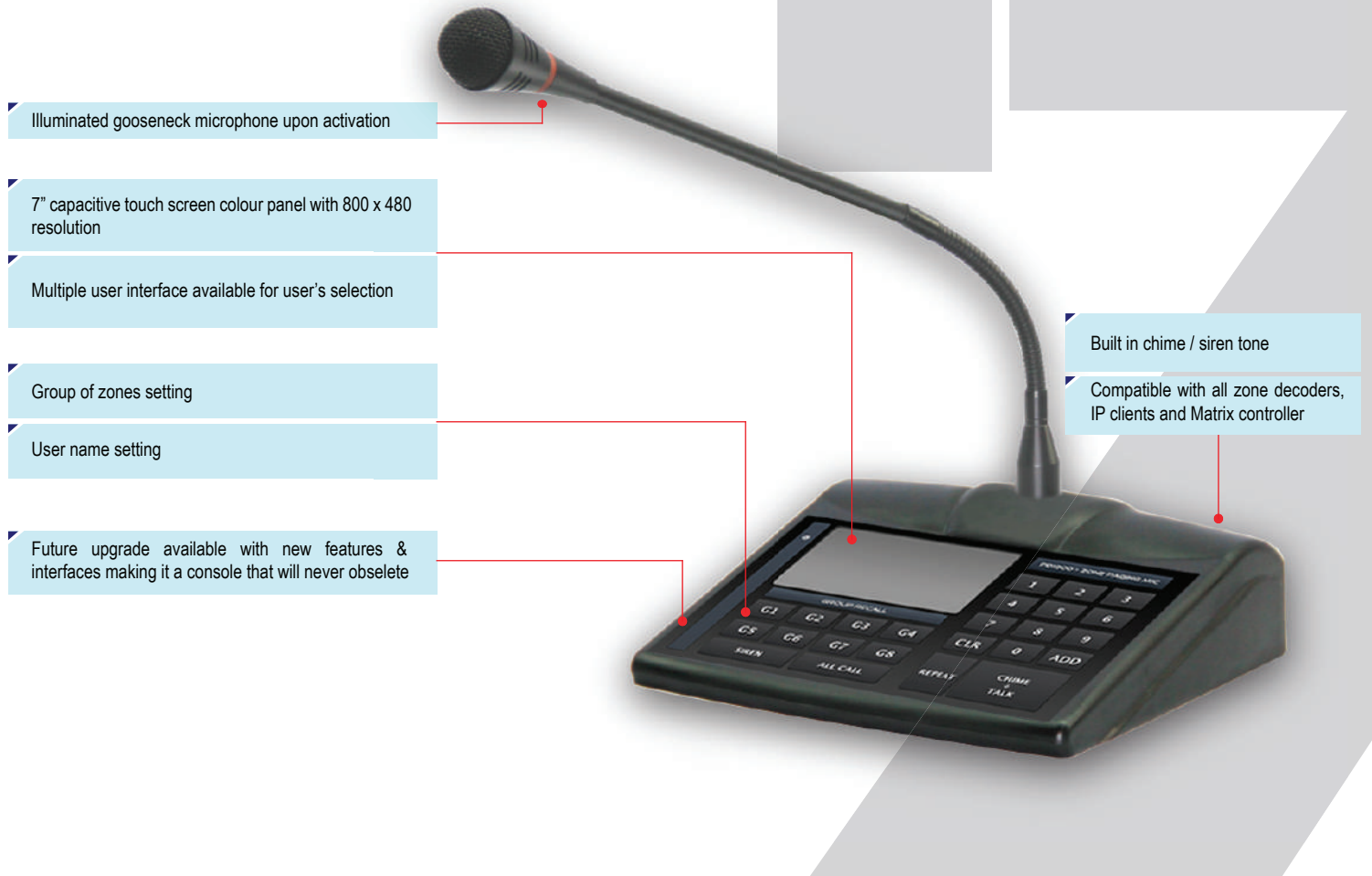

Illuminated gooseneck microphone upon activation

7" capacitive touch screen colour panel with 800 x 480 resolution

Multiple user interface available for user's selection

Group of zones setting

User name setting

Future upgrade available with new features & interfaces making it a console that will never obsolete

Built in chime / siren tone

Compatible with all zone decoders, IP clients and Matrix controller



Various Interface for settings.

Technical Specifications

Operating voltage	24V DC via EX2800 with local power adaptor
Power consumption	1.3W
Zone selection	Numerical keypad with Group, All Call
Switching selection	Capacitive touch screen
Microphone	Gooseneck condenser capsule ; unidirectional
Output impedance	600 Ohm
Output level	1.2V balanced line output
Output controls	Chime, mic volume
Data connections	RS485; 19.2 kbps
Cabling to decoder	2 pair screen; 22 AWG / Cat 5e
Recommended operating distance	500m subjected to cable size
Compatible interfacing device	MxP2288, TD6240, TD6080
Chime	4 tone up and 4 tone down
Indicators	Zone, power, audio, data, gooseneck ring LED
Displays	LCD display; white back illumination
Frequency response	100 - 12 kHz @ 1KHz +/- 3 dB
S / N ratio	>65 dB @ 1 KHz
Gooseneck mic length	370 mm
Dimension (W x H x D)	230 x 192 x 65 mm (Excluding Mic)
Weight	1.2 kg

Packing information

Qty per carton : 1 unit
 W x H x D : 512 x 83 x 288 mm
 Weight : 2.4 kg (Incl adaptor)

PD1240 PD1280

DIGITAL PAGING MICROPHONE

PD1240 and 1280 are enhanced versions of the popular PD2000 series incorporating soft touch buttons and improved sound quality. All essential features such as Priority level assignment, multipoint paging, illuminated gooseneck microphone and volume controls are included.

PD1240 is a 24 buttons zone control with 4 fixed groups with ALL CALL, suitable for small setup. For larger installations of up to 254 zones, PD1280 shall fit into the requirement which comes with large LCD panel and programmable 9 priority levels.

PD1280
Digital Paging Microphone



PD1240
24 Zone Digital Paging Microphone



Features

- Sensor touch keypad with impressive outlooks
- LED indicators for PD1240 and large LCD display for PD1280
- Suitable for multipoint paging with priority level setup
- Built in chime with selectable tone for PD1280
- Adjustable volume controls for chime and microphone
- Name setting at PD1280
- Compatible with Matrix Controller and TD Series of Zone Decoders, IP Client iPX5151

Technical Specifications

	PD1240	PD1280
Operating voltage	24V DC via EX2800 with local power adaptor	
Power consumption	1.2 W	1.3 W
Zone selection	24 zone keys, Group, All Call	Numerical keypad with Group, All Call
Switching selection	Sensor touch keypad	
Microphone	Gooseneck condenser capsule ; unidirectional	
Output impedance	600 Ohm	
Output level	1.2V balanced line output	
Output controls	Chime, mic volume	
Data connections	RS485; 19.2 kbps	
Cabling to decoder	2 pair screen; 22 AWG / Cat 5e	
Recommended operating distance	500m subjected to cable size	
Compatible interfacing device	MxP2288, TD6240, TD6080	
Chime	4 tone up and 4 tone down	
Indicators	Zone, power, audio, data, gooseneck ring LED	
Displays	NIL	LCD display; white back illumination
Frequency response	100 - 12 kHz @ 1KHz +/- 3 dB	
S / N ratio	>65 dB @ 1 KHz	
Gooseneck mic length	370 mm	
Dimension (W x H x D)	230 x 192 x 65 mm (Excluding Mic)	
Weight	0.80 kg	0.75 kg

Application Schematic

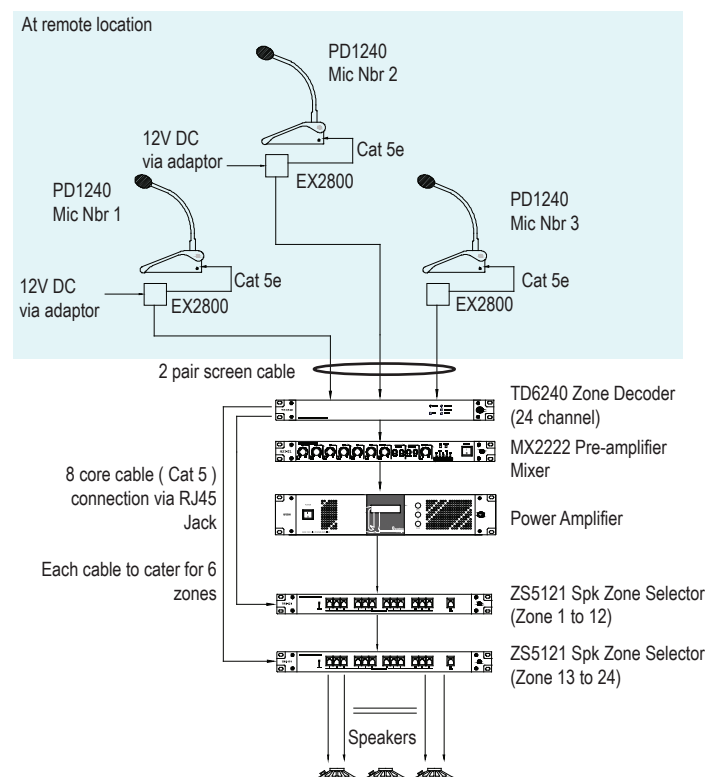

Packing information

Qty per carton	: 1 unit
W x H x D	: 512 x 83 x 288 mm
Weight	: PD 1240 - 1.90kg (incl adaptor)
	: PD 1280 - 1.95kg (incl adaptor)

DIGITAL PAGING MICROPHONE

PD2800
PD2400
PD1160

These classic digital paging microphones are suitable for remote paging setup over long distance, typically within 500m. With their harmonised protocols, they are compatible with all TD decoders and Matrix controller via RS485 data.

With multipoint paging of several PD mic, user shall be able to set priority level of each mic according to the priority needs, allowing unit with higher priority to override lesser one.



It is suitable for mid-size installations of up to 24 zones. Among its distinctive features include :

- 24 direct zone key with 4 groups with ALL CALL.
- Built in 4 tone chime with Chime and Mic volume controls
- Up to 3 priority level setting

Packing information

- Qty per carton : 1 unit
- W x H x D : 512 x 83 x 288 mm
- Weight : PD1160 - 1.6kg
- : PD2400 - 2.1kg (incl adaptor)
- : PD2800 - 2.1kg (incl adaptor)



It is suitable for large scale installations of up to 256 zones, enabling 9 groupings of 12 zones each. Features including :

- Programmable zone grouping ie. Storing selected zones in groups to enable faster access to paging.
- 9 priority level settings ie. Enables 9 multipoint paging station with 9 levels of priority
- LCD display for easy monitoring



It is a simple and dedicated paging microphone for connection to MxP2288 MatriMix system with 8 / 16 zones call station. Also compatible with TD6080.

- Built in chime
- Direct connection to MxP2288 controller.

Technical Specifications

	PD2400	PD2800	PD1160
Power requirement	24V DC via RJ45 connected to EX2800		24V DC via MxP2288 / TD6080
Power consumption	170 mA	420 mA	200 mA
Zone selection	24 individual zone key 4 groups (preset of 6 zones) ALL CALL	Numerical keypad	8 / 16 zone keys with ALL CALL
Microphone	Condenser microphone cardioid		
Output impedance	600 Ohm balanced		
Output level	1.2 V (line output)		
Output controls	Chime and mic level		
Data output	RS485; 19.2 kpbs		
Data connection	RJ45 to EX2800 via Cat 5E / 6 cable ; 2P screen to decoder		RJ45 to MxP2288 / TD6080
Operating distance (data)	Up to 1000 m (sub. to cable size)		300 m
Audio distance	Typ 500 m (sub to cable size)		300 m
Chime	4 tone up and 4 tone down	2 or 4 tones; assignable	4 tone up / 4 tone down
Indicators	Mic ring, zone switch	LCD Display	Power, source, volume, busy
Frequency response	100 ~ 12 KHz		
S/N ratio	> 60 dB at 1 KHz		
Gooseneck mic length	370 mm		
Dimensions (WxHxD)	292 x 62 x 186 mm (body only)		150 x 186 x 62 mm (body only)
Weight	1.3 kg (excl. adaptor)		1.0 kg

PM1000 analogue series are available in three variants and had been serving many installations faithfully since its creation. They are available as simple paging mic with chime to those with 6 or 12 zone selections. They are most suitable for simple and small size installations of less than 12 zones in total.

PM1000

Dekstop Paging Microphone



PM1060

6 Ch Dekstop Paging Microphone



PM1120

12 Ch Dekstop Paging Microphone



Features

- Condenser gooseneck microphone with illuminated ring
- Pre and post announcement 4 tone chime
- Adjustable chime and mic volume with balance mic / line output level
- Output level selection to mic or line signal to suit the input type of the pre-amplifier mixer
- Dry contact available when mic is active (PM1000 only)
- 6 or 12 zone selection for PM1060 and PM1120

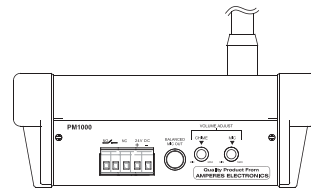

Rear View Of PM1000

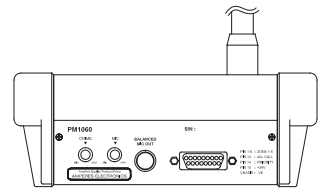

Rear View Of PM1060 / PM1120

Application Schematic

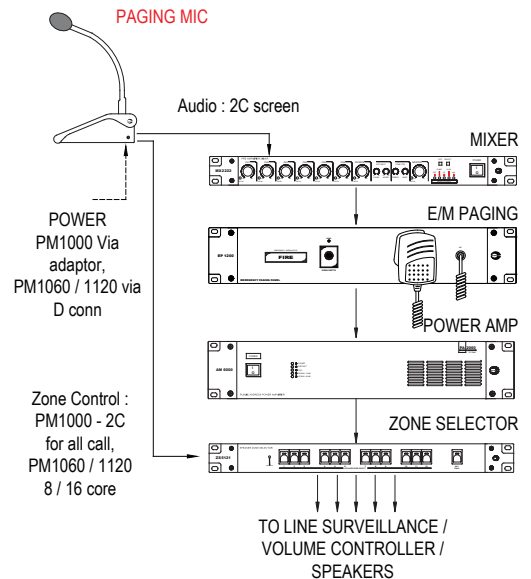

Technical Specifications

	PM1000	PM1060	PM1120
Power requirement	24V DC adaptor	24V DC via D15 conn.	
Power consumption	50 mA	150 mA	150 mA
Zone selection	ALL CALL	6 and 12 zones w ALL CALL	
Microphone	Condenser microphone cardioid		
Output impedance	600 Ohm		
Output level	1.2 V (line output) / balanced mic (0.75 mV)		
Output dry contact	3 A normally open		
Output controls	Chime and mic level		
Audio connection	1/4 " stereo phone jack		
Switching connection	2 way connector	D15 connector	
Operating distance	300 m (recommended)		
Chime	4 tone up and 4 tone down		
Indicators	Mic ring, zone switch, ALL CALL		
Frequency response	100 ~ 12 KHz @ 1KHz +/- 3 dB; 0 dB out		
S/N ratio	> 60 dB		
Gooseneck mic length	370 mm		
Dimensions (WxHxD)	150 x 62 x 186 mm (excluding mic)		
Weight	600 gms	620 gms	850 gms

Packing information

Qty per carton	: 1 unit
W x H x D	: 512 x 83 x 288 mm
Weight	: PM 1000 - 1.5 kg (incl adaptor)
	: PM 1060 - 1.15 kg
	: PM 1120 - 1.2 kg



Emergency Paging Panel is an essential tool for firemen during emergency, allowing direct paging to all zones and bypassing any active BGM or paging in progress.

EP1200 is enhanced with communication port, enabling the unit to be used with iPX5151 IP Client for a LAN based setup. This shall allow simultaneous emergency paging or siren activation for entire multiple sub racks available in the system.

Features

- Built in siren tone generator (constant signal)
- Visual FIRE indicator
- External voice message activation
- Dual mode siren tone activation
- Dry contact when paging mic is activated
- Priority paging via front panel microphone, bypassing all other audio sources
- Output level controls for siren and message / paging microphone

Rear View:

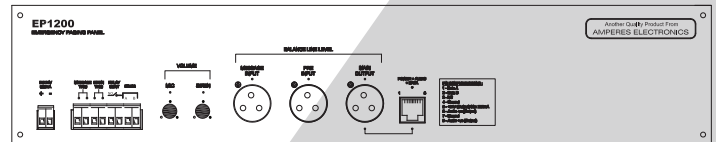

Application Schematic

Application in conventional system

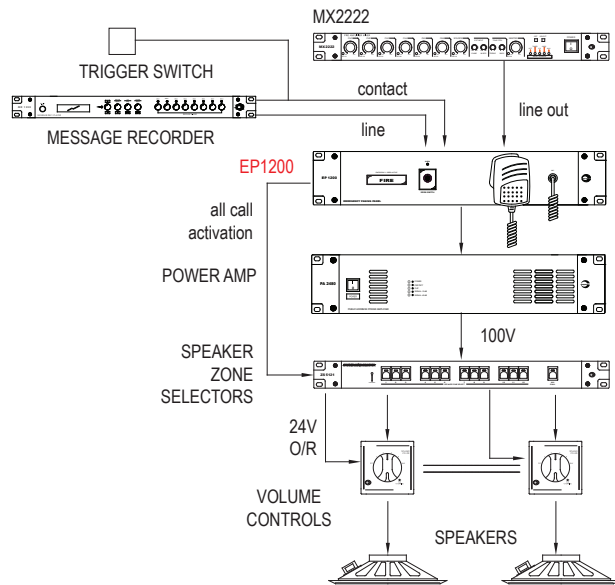

Technical Specifications

Power requirement	24V DC
Power consumption	3.5W

MICROPHONE

Mic sensitivity	-72 dB Omni directional
Impedance	600 Ohm
Frequency response	300 ~ 8 KHz

SIREN

Siren frequency	Continuous at 8 KHz
Siren duration	Continuous when activated
Siren activation	Front test switch / remote contact

Input channel	Pre-amplifier output, message recorder
Output level	Balanced line out (1.2V)
Priority sequence	Paging mic - siren - message - pre amp in
Indicators	Front FIRE with backlight illumination
Dimension (WxHxD)	482 x 88 x 180 mm
Weight	3.0 kg

Packing information

Qty per carton	: 1 unit
W x H x D	: 552 x 163 x 294 mm
Weight	: 3.6 kg



CM1400 offers 5 chimes and 2 siren tones with selectable balanced and unbalanced line output. Activation of chime shall be from front switches or via remote triggering terminal, enabling the unit to be linked to external sensors or triggering system such as alarm panel, remote mic or emergency switch. Siren has priority over chimes.

It is suitable for installation in schools, factories, hazardous areas etc.

* Customised tones available upon request.

Features

- 5 types of chimes and 2 siren
- Adjustable output volume
- Selectable output as balanced or unbalanced line
- Front panel switch activation or via remote trigger port

Application Schematic

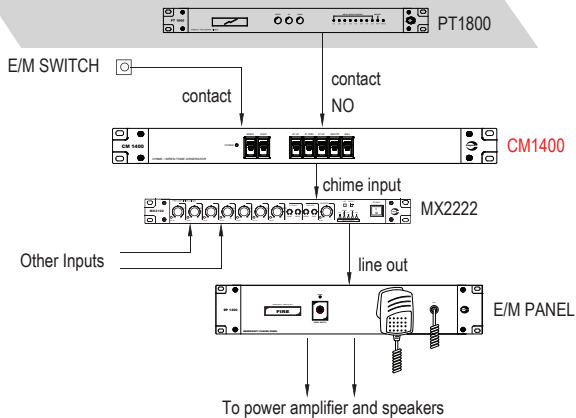

Rear View:

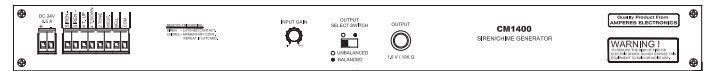

Technical Specifications

Operating voltage	24V DC ; 0.5 A
Power consumption	0.3 A
Chime type	4 tone up, 4 tone down, 2 tone Ringing bell, Westminster
Siren type	Constant siren 8 KHz Wavy siren
External activation	Dry contact
Output	Line 1V
Output impedance	10 K Ohm
Gain	+4 dB max
Dimensions (WxHxD)	482 x 44 x 180 mm
Weight	1.55 kg

Packing information

Qty per carton	: 1 unit
W x H x D	: 552 x 93 x 294 mm
Weight	: 2.15 kg

CD1001 is a rack mounted integrated DVD / CD / MP3 / AM FM tuner media player built specifically to serve BGM requirement in your PA installation. Local listening is available with headphone jack or via the built in speaker.

Features

- Plays various format of DVD / CD audio, AM / FM tuner and MP3 via USB
- Headphone jack and monitor output for pre-broadcast listening

CD1001

DVD / CD / MP3 / AM-FM Tuner



MP1020

2 CH Media Player



MP1020 is a two channel digital media player in a single rack unit. Both the modules operate independently and shall be able to play files from SD Card, USB as well as receiving FM audio.

Rear View CD1001:



Rear View MP1020:



Features

- Dual channel BGM source in a box
- Plays files from SD card, USB drive and FM radio reception
- Headphone monitoring and bluetooth

Packing information

Qty per carton : 1 unit
W x H x D : 552 x 163 x 294 mm
Weight : 5.35 kg

Qty per carton : 1 unit
W x H x D : 552 x 93 x 294 mm
Weight : 2.2 kg

Technical Specifications

MP1020	Operating voltage	24V DC 1A
	Power consumption	180mA
	Playback media	USB, mini SD Card, FM radio, bluetooth
	Supported files	MP3, WAV
	Aux audio input	RCA Stereo Line In
	Audio output	RCA Stereo
	Output voltage	LINE Out 1.2V unbalanced
	Dimension (W x H x D)	482 x 44 x 180 mm
Weight	1.8 kg	

CD1001	Playback system	DVD/ CD / CD-R / CD-RW / MP3 / Tuner	
		CD / USB	
	Frequency response	20 - 20 KHz	
	S/N ratio	70 dB	
	Channel separation	> 45 dB	
	Noise	4 mV	
	Distortion	< 0.5%	
		TUNER	
	Tuner frequency	AM : 522 - 1620 KHz FM : 87.5 - 108 MHz	
	S/N ratio	55 dB	
		Audio output	500 mV
	Output jack	Stereo, RCA jack	
	Headphone output	1/4" phone jack	
	Headphone volume	Via front VC, +4 dB gain	
	Working temperature	45°C	
Operating voltage	220 - 240V AC		
Power consumption	1.8W at 240V AC		
Dimensions (WxHxD)	482 x 88 x 180 mm		
Weight	4.4 kg		



The all new MR1301 has loads of features for flexibility in operation and performance for any demanding applications which runs on 32 bit ARM processor. It supports larger SD Card memory size of up to 16GB, offering flexible file / message arrangement or naming.

User shall be able to group different messages with delays in between for every single message bank with high quality MP3 format of 320 kbps. All settings can be done easily, offline through the SD Card and the configurator software provided. Another key feature is the auto firmware updates, making MR1301 a tool that would work to contemporary needs.

Features

- 32 bit ARM chip for faster and multitasking processing of data
- Up to 16GB of memory space using Micro SD card
- Message playback via front direct access button and rear remote triggering
- High quality MP3 playback of up to 320 kbps
- 64 kbps IMA ADPCM voice recording for better clarity
- Flexible message configuration in every memory bank eg. Multiple files in a single button
- Priority message playback with dry contact activation
- Playback controls ie. Volume, Repeat, Bass and Treble
- RS485 output with PC link for remote monitoring or using iPX5400 UART-IP converter for monitoring and control via LAN (Application software : PMX II LAN)
- Auto firmware update / detection upon power up
- Alternative setup at PC via "MR1301 configuration" software

Technical Specifications

Operating voltage	24V DC
Power consumption	1W
Data communication	RS485 at 19.2 kbps
Inputs	Line inputs; unbalanced via RCA jack Microphone input; via front phone jack
Processor	32 bit ARM
Message trigger	16 front and rear message
File format	MP3, WMA, WAV
MP3 quality	320 kbps
Voice recording	IMA ADPCM 16 KHz Sampling Rate Bit Rate : 64 kbps
Files in single bank	Up to 20 per message / button
Delay set up in playback	Yes
Priority message cut	Yes
Software interface	Yes
Remote view / control	Yes
Indicators	LED at switches, LCD display
Memory	MicroSD up to 16 GB
Dimension (W x H x D)	482 x 44 x 180 mm
Weight	2 kg

Rear View:

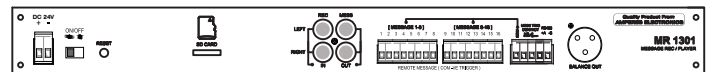

Application Schematic

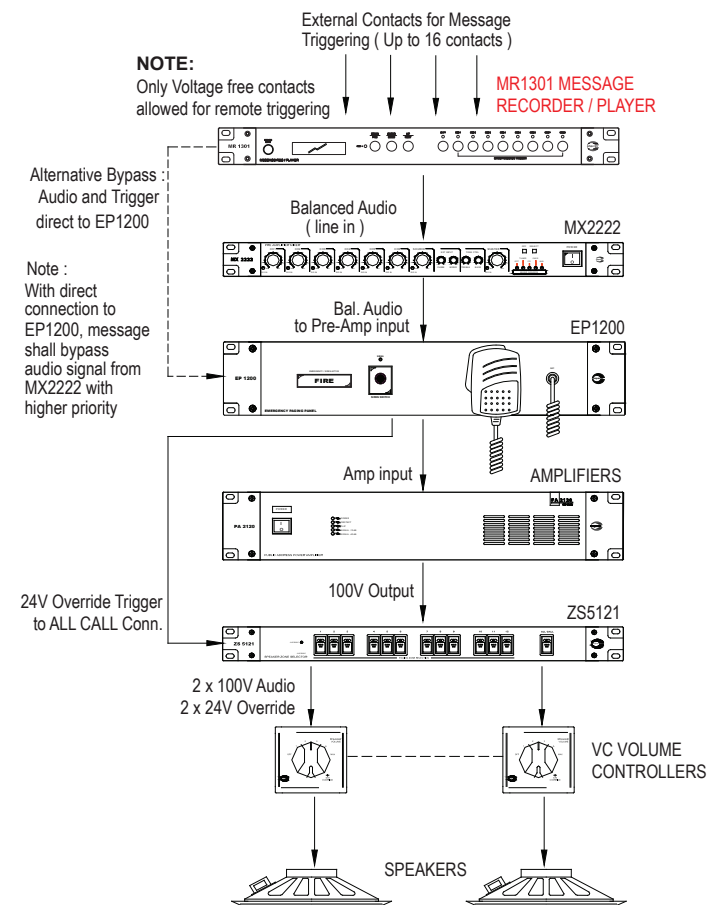

The above diagram shows typical schematic using MR1301 as message player, either for general repetitive message playback or for emergency voice evacuation purpose.

Packing information
 Qty per carton : 1 unit
 W x H x D : 552 x 93 x 294 mm
 Weight : 2.6 kg



The all new PT1801 now packed with better features, notably with its setup or programming process. The user friendly "PT1801 Configurator" software is available for download from website and programming of schedules, upload or recall programs can be done at breeze.

PT1801 is useful for schools, factories, malls, etc. which shall work to provide reliable time reminders for various events of the day. Its 250 programmable steps with 8 output contacts shall cater for needs of various industries.

Features

- 8 output triggering ports with user selectable contact options
- 250 preset triggering times with free assignment to any of the output ports
- User interface software for ease of programming
- RS485 data for remote monitoring
- Westminster chime output with adjustable volume

Application Schematic

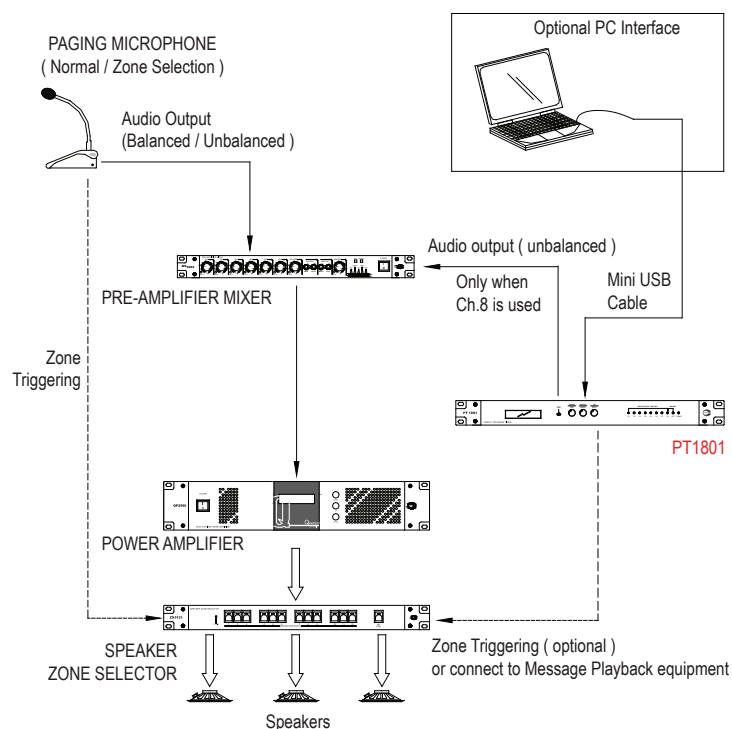

Rear View:

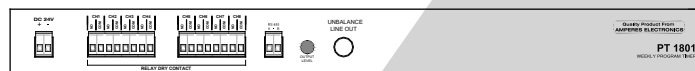

Technical Specifications

Input voltage	24V DC ; 0.5A
Power consumption	4.8W
Output channels	8
Triggering mode	ON, OFF, pulse (3 seconds)
Memory	250 preset time
Contact rating	3A
Indicators	LED for triggered channel, Melody, Standby
Output chime	Westminster (Ch. 8 only)
Chime output level	Line level ; 1.2Vrms
Volume attenuation	off to 0 dB
Output connection	1/4" phone jack ; unbalanced
Impedance	1K Ohm
Clock backup	CR1220 button battery
RTC accuracy	± 2ppm
Data link	RS485
Baud rate	19.2 kbps
Dimensions (WxHxD)	482 x 44 x 180 mm
Weight	2 kg

Packing information

Qty per carton	: 1 unit
W x H x D	: 552 x 93 x 294 mm
Weight	: 2.5 kg



FI6000 is a phase evacuation controller which can be integrated with various Amperes equipment such as zone decoder and voice message player for interfacing with Fire Alarm System.

As part of requirement of EN54, it is necessary that voice alarm to be broadcasted according to zone(s) for orderly evacuation or warning purposes. FI6000 performs the task required by triggering appropriate announcement and intended broadcast zones.

FI6000 can be configured via configurator software and is flexible in its setup.

Features

- Integration with Amperes products via RS485 interface and Fire Alarm System via dry contacts
- Available in 24 zone per panel and scalable to cater for larger number of zones
- Easily programmable for phased evacuation announcement
- Provided with FI6000 Configurator software for easier setup
- Bicolour LED status indication for each incoming sensors

Technical Specifications

Input :

Operating voltage	24V DC
Current source idle	20mA
Current source channel and relay trigger	0.10A
Power consumption idle	0.48W
USB input	USB to RS485 Driver
Communication control	RS485
Baud rate	19200 bps
Unit cascade control	Software Control
Channel input	24 Channel
Software configuration	FI6000 Configurator

Output :

Channel output	4 Channel
Contact rating	3A
LED indicator	28 LEDs

Case :

Dimension	482 x 44 x 180 mm
Weight	1.85 kg

Packing information

Qty per carton	: 1 unit
W x H x D	: 552 x 93 x 294 mm
Weight	: 2.5 kg

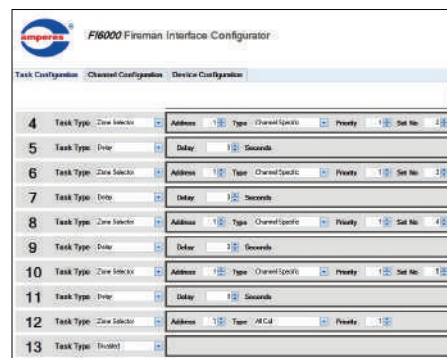

Configurator interface enables a sequence of events for any triggered alarm from FA Panel.



Application Schematic

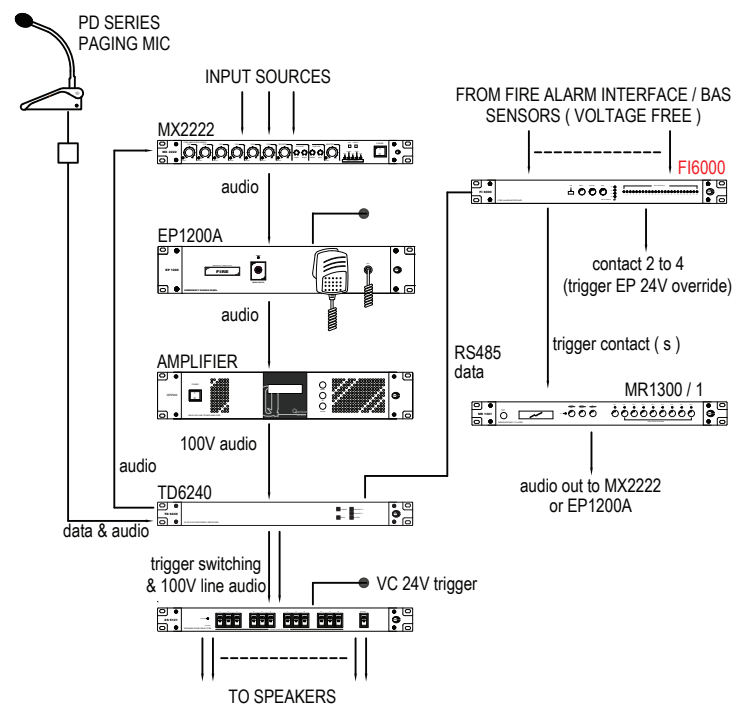

Rear View:



GENERAL TERM USED IN PUBLIC ADDRESS SYSTEMS

ROOT MEANS SQUARE (RMS) :

Average value of ac voltage, it is 0.707 time of the peak voltage of a constant sine wave.

IMPEDANCE (Ohm with symbol Z) :

A measurement of total resistance to current in a circuit with inductance and capacitance, such as speakers and microphones. The value differs for different frequencies, and thereby would normally be rated at Ohm @ 1 KHz.

SENSITIVITY :

The minimum signal required for producing a fixed output level and is specified in various terms. In Microphones (mV/Pa), is amount of mV produced by a Pascal of sound pressure (94 dB) in axis with the transducer. In Speakers (dB, 1W @ 1m) is the sound output in dB produced by 1W of power and measured in axis of 1 m away. In professional Amplifiers (dBu or V) is the input signal required for the power amplifier to reach its rated output.

SIGNAL TO NOISE RATIO (S/N Ratio) :

Measured in dB, is the ratio of signal to noise at same point of signal. It is normally measured at 1 kHz with 1V input signal. Higher S/N ratio is always preferred.

DECIBELS (dB) :

Use to express the ratio between two signals, such as Voltage, Power, Current, etc. It is expressed in dB SPL for Sound Pressure Level, dBV for relativity to 1V and etc.

SOUND PRESSURE LEVEL (SPL) :

A measurement of loudness in relation to the threshold of human hearing at 2 uBar. It varies with frequencies and thereby in audio, it is expressed as RMS value in dB SPL. See also the SPL chart.

TOTAL HARMONIC DISTORTIONS (THD) :

Expressed in %, it is the ratio of a fundamental frequency to the level of all harmonic frequencies produced by the equipment. Lower percentage is better.

FREQUENCY RESPONSE :

Is used to indicate how well an equipment or speaker response to the audio input signal, usually 20 to 20 KHz. It is usually measured at 1KHz reference, 1V input level with +/- 3 dB.

BALANCED SIGNAL :

Refers to cable carrying audio signal with 3 conductors ie. Hot, Cold and Ground or Shield. It offers better immunity against external interference and is preferred choice for long cabling.

UNBALANCED SIGNAL :

Refers to audio signal in cable with Hot and Ground (Shield) conductors. It is recommended for short distance cabling as it is subjected to interference.

SPEECH TRANSMISSION INDEX (STI) :

STI is used to measure speech intelligibility by injecting a test signal at source point and measurement is made at the listening plane. The measured value is within the range of 0 to 1.



SOUND LEVEL COMPARISON CHART

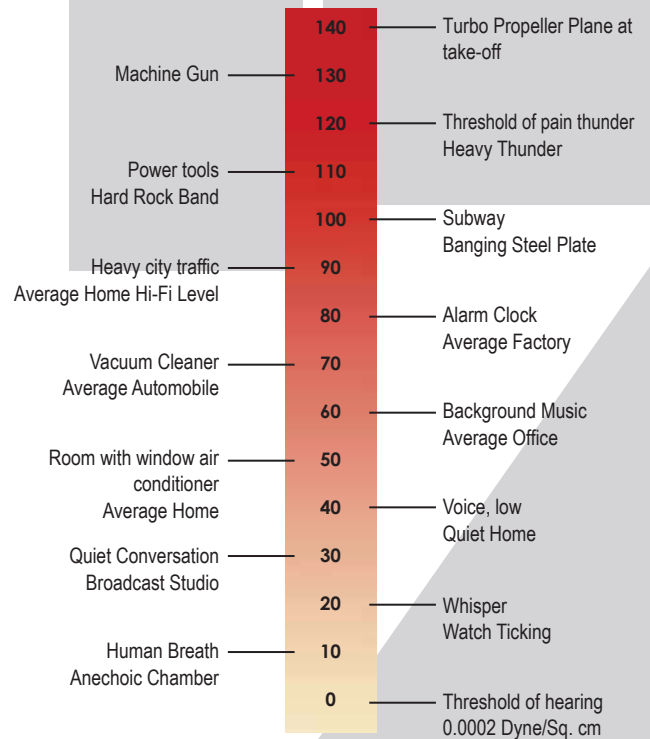

Sound Pressure Level (SPL) is normally expressed in dB, in relation to the lowest sound level a human ear can hear ie. 20 uBar. The chart below shows typical SPL level from various source of sound.

AUDIO LEVELS :

In professional audio, line level is referred to as +4 dBu which is a reference of how much it is above or below the reference level of 0.775V. 4 dBu = 1.25V rms. The value of consumer or semi-professional differs and is lower than this, eg. 0 dBV = 1 V rms. Consumer line level is typically -10dBV or 0.32V.

0.775V rms is used as reference as it is used to generate 1 mW (0 dBm) over the load of 600 Ohms. ($P = V^2 / R$).

TERMS RELATED TO SPEAKER POWER

AVERAGE POWER :

Often referred to RMS Power as rms value of voltage and current are used to calculate the power.

PROGRAM POWER :

Also known as Music Power and is normally twice the amount of Average Power. It is used to select suitable amplifier rating.

PEAK POWER :

Defines the instantaneous power delivered to speaker at highest level of output.



DA2208 shall be used to amplify incoming audio signal of line level and thereafter linked to several amplifiers to avoid sound distortion. It consists of 2 sets of 1 in 4 out configuration and can be set as 1 in 8 out format. Each output channel has its individual bass and treble controls, facilitating tone setup of the amplifier to suit the type of speakers used as well as the acoustic environment.

Features

- Operates as dual channel 1 input 4 output or single channel 1 input 8 output
- Individual bass and treble control with volume adjustment
- Direct input signal to output whenever DC power input not available or whenever power failure occurs

Technical Specifications

Operating voltage	24V DC
Power consumption	2.4W
Configuration	1 in x 8 out or 2 in x 4 out
Input level	Line : 1V rms max
Input impedance	10 K Ohm
Output gain	+ 4 dBu
Output impedance	10 K Ohm
Controls	Bass, Treble, Channel volume
Frequency response	150 ~ 19 KHz (+/- 3 dB at 1 KHz)
Dimensions (WxHxD)	482 x 44 x 180 mm
Weight	1.55 kg

Rear View:

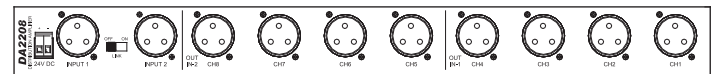

Application Schematic

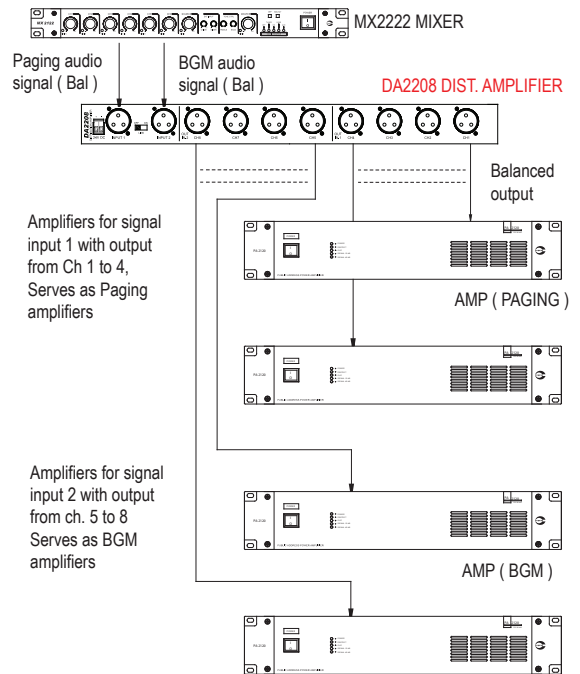

The above illustration is for Uninterrupted Paging setup. In normal setup with single input, use the link switch to form 1 input 8 outputs configuration. Each output from DA2208 can be linked up to 6 power amplifiers.

Packing information
 Qty per carton : 1 unit
 W x H x D : 552 x 93 x 294 mm
 Weight : 2.15 kg



This compact 1 hu pre-amplifier mixer features 6 mic, 4 BGM sources, chime and external line inputs and is suitable for any application, such as meeting room, lecture theatre, hall of prayer and definitely commercial fixed PA installation.

Its dual output feature can be used for uninterrupted paging setup, i.e. BGM and paging announcement. Adjustable priority muting level is available for paging announcement to override BGM and other lower priority sources. Adjusting it to minimum and the unit shall work like any other mixing unit and it comes with 12V phantom power supply for mic input 1 to 4.

Features

- 12 inputs of mic, BGM sources, ext.chime and mixer link
- Expandable to form more channels for larger setup
- Auto mic muting with adjustable mixing level for mic Ch.1, 2, ext.chime and mixer link
- Priority muting with disable option for normal mixing mode
- Switchable phantom power for mic channel 1 to 4
- Dual output ; mixed line and BGM output for uninterrupted paging setup
- Independently adjustable BGM output level with balanced line
- Built in daisy chain source selector with last selection memory
- Bass and treble tone control
- AC and DC operation for uninterrupted operation during power failure

Application Schematic

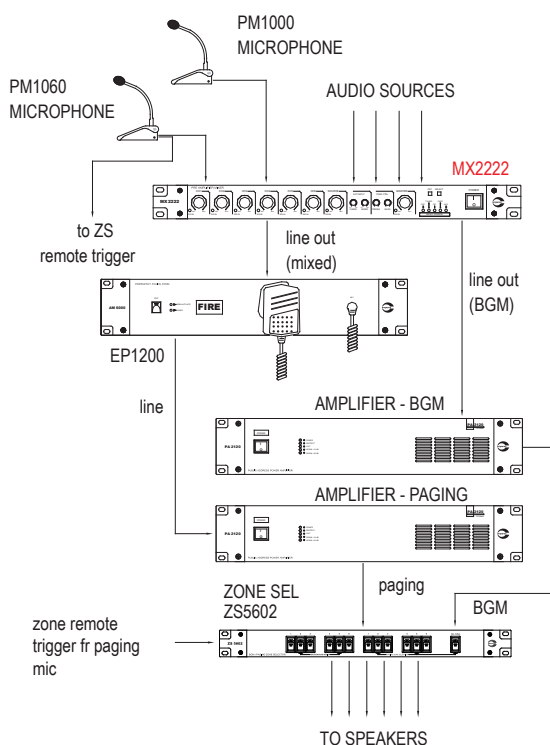
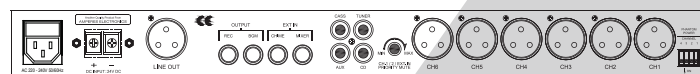

Illustration for uninterrupted paging system.

Rear View:



Technical Specifications

Operating voltage	220 - 240V AC or 24V DC
Power consumption	2.4W on 240V AC / 100 mA on 24V DC
Input channels	6 x mic ; 4 x BGM ; ext chime in ; mixer link
Input impedance	Mic : 600 Ohm BGM : 47 K Ohm unbalanced Chime input : 10 K Ohm unbalanced Mixer link : 600 Ohm balanced
Sensitivity(1.2 mVrms output)	Line : 530 mVrms Mic : 2.5 mVrms
Output level	1.2V XLR balanced (mixed output) 1.0V phone jack balanced (BGM output)
Output impedance	600 Ohm balanced
Controls	Mic channel ; chime ; mixer input Master mixed ; BGM ; Bass and treble controls
Phantom power	12V DC switchable at mic 1 to 4
Frequency response	175 - 15 KHz (+/- 3 dB at 1 KHz) with low cut
S/N ratio	> 60 dB at 1 KHz
Dimensions (WxHxD)	482 x 44 x 180 mm
Weight	2.5 kg

Packing information

Qty per carton : 1 unit
W x H x D : 552 x 93 x 294 mm
Weight : 3.1 kg

Amperes PA320 is a mini amplifier used to amplify BGM signal to a speaker of 4 or 8 Ohm, such as from TV output to a bathroom speaker in a hotel room. Amperes VC7805 volume controller and VP7810 BGM-Speaker patch panel can be installed if required to allow emergency paging to be announced at the speaker.

Other applications include simple mic calling system at counters or as an amplifier module to some other system which need to broadcast audio output to a speaker, ie. queue management system or telephone intercom.

Features

- Available in 20W 4 Ohm rating or 30W 100V line (PA330)
- Adjustable volume control for volume preset
- Compact size for easy installations

Application Schematic

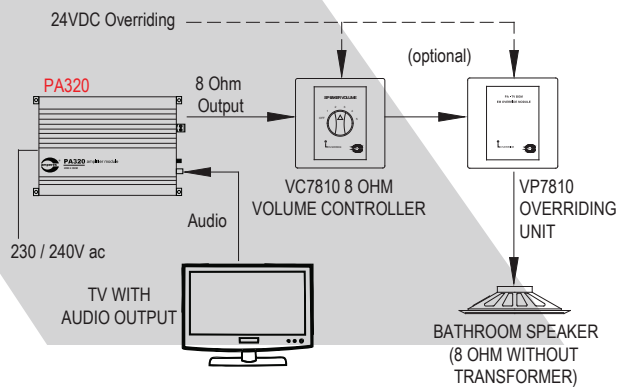

PA320
20W 4Ohm Mini Amplifier



PA330
30W 100V Line Amplifier

Amperes PA330 has higher rating of 30W 100V line which accepts unbalanced line input. It can be used as remote amplifier in a decentralised PA system. Among applications include classroom paging and paging for remote station.

Using LC1000 (step down module) shall allow PA330 to accept 100V line input and thereby a very large network of paging can be implemented in a wider area.

Technical Specifications

	PA320	PA330
Rating	20W 4 Ohm	30W 100V Line
Operating voltage	220 - 240V AC	
Current consumption	0.14A	0.17A
Input signal	Mono ; unbalanced line	
Input sensitivity	40 mV	
Max input	1.2V	
Input impedance	100 K Ohm	10 K Ohm
Frequency response @ 1KHz +/- 3 dB	100 ~ 18 KHz	150 ~ 15 KHz
Controls	Input volume preset	
Dimensions (WxHxD)	130 x 55 x 95 mm	160 x 95 x 170 mm
Weight	790 g	2.4 kg

Packing information

PA320
W x H x D : 552 x 163 x 294 mm
Qty per carton : 20 unit
Weight : 16.4 kg

PA330
W x H x D : 550 x 420 x 220 mm
Qty per carton : 10 unit
Weight : 24.1 kg

120 / 240 / 360 / 480 / 600W 100V Line POWER AMPLIFIERS

PA2120
PA2240
PA2360
PA2480
PA2600 (New)

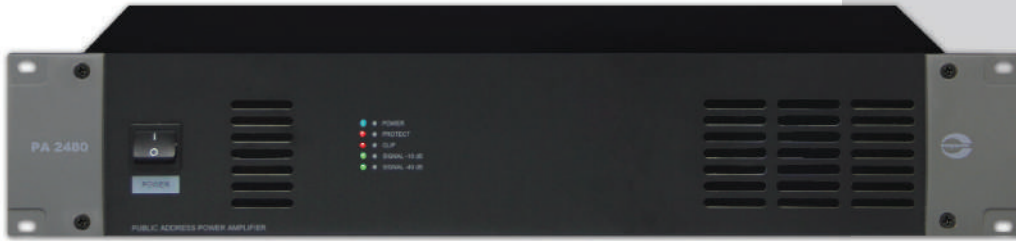

PA2000 series of various ratings of line power amplifiers has been audio workhorse reknown for its reliability and performance. 600W version has been added to cater for larger load.

With our continuous product improvement effort, additional protection circuitries had been incorporated to fit into different installation conditions. Among them is the inrush current limiter. Peace of mind by this reliable machine is ensured, with a fraction of cost as compared to other makes of its class.

Features

- Available in various ratings ; from 120W to 600W 70 or 100V line
- 4 Ohm speaker connection available with 25V output
- Thermal protection by muting input signal (typically 85 deg at heat sink)
- Momentary short circuit protection
- In rush current limiter
- Temperature dependent dual speed cooling fan
- Balanced input signal with gain control and selectable grounding option
- AC and DC operation for uninterrupted operation during power failure

Rear View:

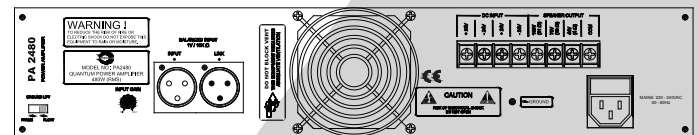

Packing information

Qty per carton : 1 unit
W x H x D : PA2120 / PA2240 / PA2360 / PA2480 / PA2600 : 550 x 180 x 455 mm

Weight : PA2120 - 13.4 kg
PA2240 - 14.6 kg
PA2360 - 17.4 kg
PA2480 - 19.4 kg
PA2600 - 20.2 kg

Technical Specifications

	PA2120	PA2240	PA2360	PA2480	PA2600
Operating voltage	220 - 240V AC or 24V DC back up supply				
Power consumption (240V AC)	280VA (1.3A)	420VA (1.75A)	560VA (2.3A)	700VA (3.0A)	960VA (4A)
Current consumption (24V DC)	8A	14.5A	19A	24A	30A
Standby current (24V DC)	0.2A	0.25A	0.3A	0.32A	
Input signal	1V / 10K Ohm; balanced via XLR female				
Input gain controls	-40 to 4 dBu				
Rated output (100V, RMS)	120W	240W	360W	480W	600W
4 Ohm output voltage	22V	31V	38V	43.8V	48V
Output impedance (max load)	83 Ohm	42 Ohm	27 Ohm	20 Ohm	16.6 Ohm
Frequency response	70Hz - 15 KHz @ 1KHz +/-3 dB				
S/N ratio	>70 dB @ 1 KHz, 1V				
THD + N	<0.18 %				
Protections	Thermal, Short circuit, Overload, Fuse, In rush current				
Cut off temperature	75 Deg C				
Cooling system	Auto temperature controlled fan speed				
Indications	LED : Power, Signal level				
Dimensions (W x H x D)	482 x 88 x 335 mm				
Net Weight	12 kg	13.3 kg	16.2 kg	18.2 kg	19 kg

60 / 120W 100V Line MULTI CHANNEL POWER AMPLIFIERS

DP2406
DP2212



DP2406 is a quad channel with power rating of 60W 100V line per channel whereas DP2212 is dual channel of 120W 100V line per output. With its Class D amplification, it has various advantages over conventional power amplifiers, notably its higher power efficiency, lesser heat dissipation as well as flatter frequency response.

It is most suitable for Matrix setup, which multiple channels of amplifiers are required and with lesser unit count of amplifiers, it translates into more rack space savings and lower overall setup costs.

Features

- Class D amplifiers for wider frequency response
- Low power loss with higher efficiency circuits
- Available in 2 x 120W or 4 x 60W 100V Line
- High ambient temperature operating condition
- AC and DC operation

Rear View DP2406

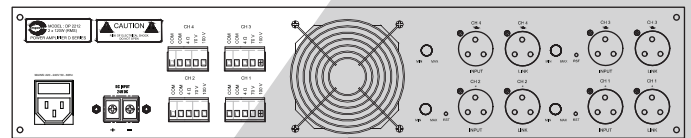

Rear View DP2212

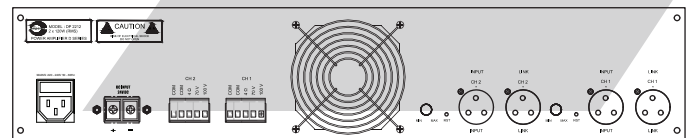

Technical Specifications

	DP2406	DP2212
Rating	4 x 60W 100V line	2 x 120W 100V line
Operating voltage	220 - 240V AC or 24V DC	
Current consumption	1.4A on 240V AC	
Current (Load / Standby)	10.2A/0.7A on 24V DC	
Input	4 x XLR	2 x XLR
Input level (max)	1.25 Vrms Balanced	
Outputs	100V, 70V, 30V	
Frequency response @ 1KHz +/- 3dB	100Hz ~ 16kHz	
Protection	Thermal, short circuit AC & DC fuse	
Indicator	Power, audio input level, over temperature, amplifier faulty	
Cooling system	Via continuous operating fan	
Dimension (WxHxD)	482 x 88 x 335 mm	
Weight	13.3 kg	12 kg

Packing information

Qty per carton : 1 unit
 W x H x D : DP2212 / DP2406
 : 550 x 180 x 455 mm
 Weight : DP2212 - 13.7 kg
 DP2406 - 15 kg



MA2000 Series, available in power rating of 60 to 240W 100V line is suitable for small setup such as showrooms, shops, function rooms or small mosques. It has 3 selectable zone outputs with remote selection from PM Series of paging microphones with muting feature.

Optional media player module for USB / SD Card MP3 playback and AM FM tuner is available for version with prefix P (eg.MA2024P).

Features

- 6 mic / line selectable input channels, with front mic jack, phantom power
- Priority muting for mic input 1 with adjustable muting level
- 3 zone speaker output with ALL CALL and remote triggering port
- 100V line output with aux 4 Ohm speaker terminal
- Tone and bass controls
- AC / DC operation

Packing information

Qty per carton : 1 unit
 W x H x D : MA2060 / MA2012 / MA2024
 : 550 x 175 x 420 mm
 Weight : MA2060 - 11.0 kg
 : MA2012 - 12.1 kg
 : MA2024 - 14.0 kg

Rear View:

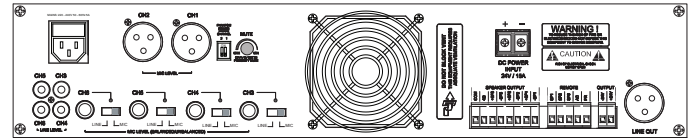

MA Series is available with optional media player module

MA 2012P / MA2024P :

Variants with USB / SD Card / Tuner / Bluetooth Player

Technical Specifications

	MA2060	MA2012	MA2024
Ratings	60W 100V line	120W 100V line	240W 100V line
Operating voltage	220 - 240V AC or 24V DC		
24V DC requirement	4A	8A	15A
Current (Load / Standby)	1.3A / 0.4A	2.2A / 0.4A	6.1A / 0.3A
Input channel	6 : 2 MIC (XLR), 4 MIC/Line Selectable (RCA/Phone Jack)		
Input phantom power	Mic 1 and 2 ; 12V DC		
Input sensitivity / impedance	2 x Mic (XLR) & 4 x Mic (Phone jack) : 4 mVrms 4 x LINE (RCA) : 350 mVrms		2 x Mic (XLR) & 4 x Mic (Phone jack) : 20 mVrms 4 x LINE (RCA) : 150 mVrms
Tone controls	Bass (100 Hz) ; Treble (10 KHz) +/- 3 dB		
Outputs	3 Zone 100V line, 4 Ohm		
Output selection	Front and remote triggering		
Frequency response @ 1KHz +/- 3dB	175 ~ 18 KHz		70 ~ 15 KHz
Protections	Thermal, short circuit, AC and DC fuse		
Indicators	AC mains, clip, protect, audio input level		
Cooling system	Dual speed fan with heat sensing		
Dimensions (WxHxD)	424 x 88 x 300 mm		
Weight	9.8 kg	10.9 kg	12.8 kg

60 / 120W 100V Line BASIC MIXER AMPLIFIERS

MC2106
MC2112



MC2000 Series offer simple mixing amplification for small setups or functions such as shops, boutiques, meeting rooms or a small gathering venues. Two versions are available ; 60 and 120W 100V line outputs.

Though being basic, it is equipped with various protection features such as thermal and short circuit protections.

Features

- 6 inputs for mic and line with phantom power for input 1
- Tone and bass controls
- 70 / 100V line output with 4 Ohm terminal with audio line output
- Short circuit, thermal protections

Rear View:

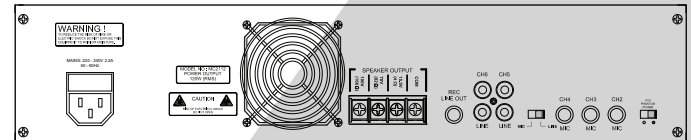

Technical Specifications

	MC2106	MC2112
Rating	60W 100V line	120W 100V line
Operating voltage	220 - 240V AC mains	
24V DC requirement	-	
Current (Load / Standby)	1.2A / 0.1A	2.2A / 0.1A
Input channel	6 inputs ; 4 Mic phone jack, 2 line selectable (RCA)	
Input phantom power	Mic 2 : 12V DC	
Input sensitivity @ 1W / 4 Ohm	Mic : 430 mV Line : 650 mV RCA : 642 mV	
Tone controls	Bass (150 Hz) ; Treble (10 KHz) \pm 3 dB	
Outputs	4 Ohm / 100V line	
Frequency response @ 1KHz +/-3 dB	120 Hz - 15 KHz	
SNR	76 dB @ 1 kHz, 1V	
THD+N (at rated power)	0.02%	
Protections	Thermal, short circuit, AC and DC fuse	
Indicators	Power, Audio Input Level	
Cooling system	Fan with dual speed	
Dimensions (WxHxD)	424 x 88 x 180 mm	
Weight	7.05 kg	7.80 kg

Packing information

Qty per carton	: 1 unit
W x H x D	: MC2106 / MC2112 : 552 x 163 x 294 mm
Weight	: MC2106 : 7.80 kg : MC2112 : 8.65 kg

TECHNICAL INFO

SPL (dB) TO POWER AND DISTANCE

The Sound Pressure Level (SPL) shall drop 6 dB whenever the distance from source is doubled. It can be calculated from the formula :

$$\text{SPL drop} = 20 \log D \text{ (D= distance in metre)}$$

SPL (dB) shall increase 3 dB when the power to speaker is doubled, calculated from :

$$\text{SPL} = 10 \log W \text{ (W = power input)}$$

Distance (m)	2	4	8	10	15	20	30	40	50	60	80	100
dB Loss	6	12	18	20	23.5	26.0	29.5	32	34	35.6	38	40

Power (W)	1	2	4	8	10	15	20	30	40	50	80	100
dB Increase	0	3	6	9	10	11.8	13	14.8	16	17	19	20



SPEAKER CABLING IN 100V LINE SYSTEM

Cables used in PA installations are subjected to losses as similar to the cablings in electrical installations. The factors affecting the percentage loss include the cable size, length, cable materials, input voltage, load and temperature. A typical loss chart with relation to cable size is shown below. (Copper conductors in single phase). For accuracy, please refer to the manufacturer's data sheet.

Cable Gauge AWG	Conductor Size (mm sq)	Impedance Ohm / 1000ft	Length in Meter for 0.5 dB Power Drop (Appr 81% at Load)				
			500W Load 20 Ohm	300W Load 33 Ohm	200W Load 50 Ohm	100W Load 100 Ohm	50W Load 200 Ohm
10	5.26	1.00	190	320	490	990	1990
11	4.17	1.26	150	260	390	780	1580
12	3.31	1.59	120	200	310	620	1250
13	2.62	2.00	90	160	240	490	990
14	2.08	2.53	75	130	190	390	780
15	1.65	3.18	60	100	150	310	620
16	1.31	4.02	45	70	110	240	480
17	1.04	5.06	35	60	90	170	390
18	0.82	6.39	26	50	70	150	310

	125W power		250W		500W	
	1 dB loss	3 dB loss	1 dB loss	3 dB loss	1 dB loss	3 dB loss
10	1727	6045	862	3017	429	1502
12	1087	3805	542	1897	270	945
14	683	2391	341	1194	170	595
16	430	1505	215	753	107	375
18	269	942	134	469	67	235
Total Impedance	800 Ohm		400 Ohm		200 Ohm	

The table provides an approximate cable length permissible for specified loss of signal in 100V line speaker installation.

FIBER OPTIC CABLES IN PA INSTALLATIONS

Laying of copper cables may not be wise in installations such as railway stations communications, sparsely located buildings or remotely located paging points. They may pose hazards like lightning strike, interferences as well as signal drop, and thus affect the performance and lifespan of the installation.

Fiber optic cabling is an alternative solution and applying IP to the system would make the PA setup to be cost effective, safer, expandable and more efficient.

Followings are the items required for fiber optic installation :

- IP PA Server / Controller - Amperes iPX5101 (one per system)
- IP PA Client / Adaptor - Amperes iPX5151 (one for each location)
- Network Switch, 10/100T or higher
- Cat 5e to Fiber Converter (if Fiber optic network switch unavailable)
- Fiber optic cable (Single / Multimode) - 2 core

For short distance (typically around 2 km) multimode cable shall be used and single mode type for longer distance.



POSITIONING OF SPEAKERS

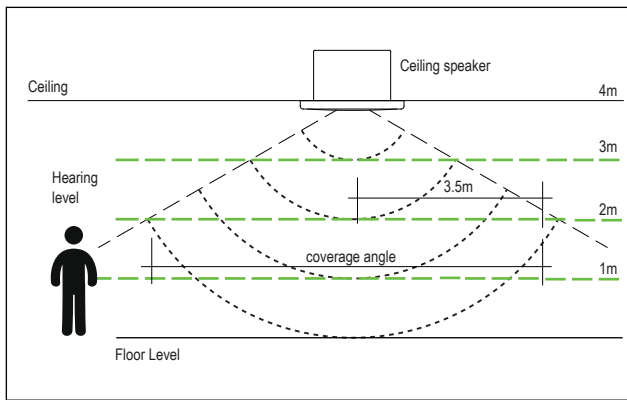

The criteria to be considered in determining the number of speaker required in any installation shall include:-

- 1) The ceiling height
- 2) Acoustical factor of the environment
- 3) Type of speakers, eg. dispersion angle and SPL level.
- 4) Expected environment such as factory, office or shopping complex.

In order to hear properly, the sound source from speaker shall be 6 dB above the background noise.

If the background noise is around 70 dB, such as in a shopping area with average crowd, the person shall be listening to the speaker sound at approximately 76 dB, at around 1.5 to 2m above floor level.

If the power input is 3W, the SPL (1KHz) at 2 m from speaker shall be approximately 93 dB. With music source, the average SPL shall be 3 dB below ; thereby the hearing shall be around 89 dB, which is rather comfortable level in a shopping mall.

From this, the coverage area can be estimated ; ie. approximately 7m diameter or 38 sq m. Further to this, the distance of speaker can be ascertained by dividing the area of the mall to the area of coverage by each speaker.

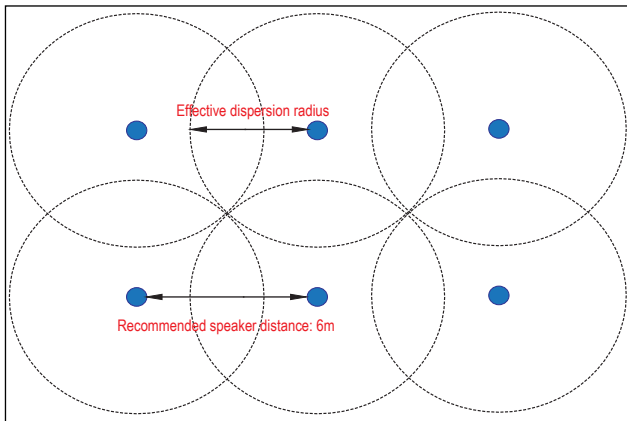

FLOOR MAPPING

A general guide to calculate speaker quantity of a floor area. Ceiling height, dispersion angle and speaker characteristics determine the dispersion radius.

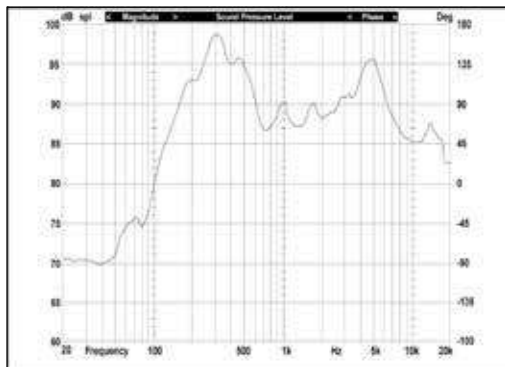

SPL CHART

It tells the frequency response of a speaker, measured at 1W / m, +/- 3dB at 1 KHz reference point.

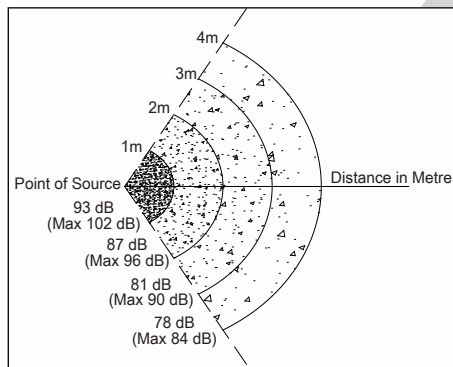

SPL VS DISTANCE

A general guideline showing the drop of SPL level over distance, measured in meter.

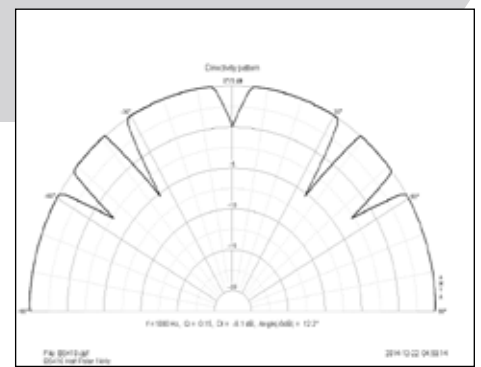

POLAR CHART

Shows the effective dispersion angle of a speaker. Full 360 deg chart is often used to check full angular characteristics of speaker.

POSSIBLE CAUSE OF SPEAKER DAMAGE

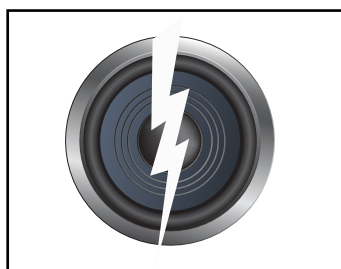

Speaker may be damaged while in operation and can be associated to excessive power delivery in appropriate frequencies the driver or due to natural disaster such as lightning strike. To prevent or at least to pro long the speaker lifespan the followings should be taken into consideration:-

- Avoid excessive input power to speakers
- Ensure audio signal delivered is within the frequency baudpass of the speaker (e.g. sub bass)
- Do not allow amplifier to clip, ie ensure power rating of amplifier is higher than the total load
- The amplifier with DC output protection, and preferably with high pass and low pass filters

AC3801



STANDBY AMPLIFIER CHANGEOVER UNIT



Introduction

Introducing the all new manual changeover, AC3801 which is a combination of its predecessors AC3601 and AX700 in a unit. Now it comes with 8 duty amplifier inputs with one standby and other features available in previous versions remained, such as priority takeover, standby amplifier overloading protection and cascade expansion.

It is suitable for normal power amplifier setup for manual changeover to faulty unit or those amplifiers with auto fault sensor contact such as QP2000 series.

Features

- Cater for 8 duty and 1 standby amplifier
- Expandable for 1 standby to serve more than 8 duty units
- Overload protection by allowing only a single take over
- Prioritized changeover - unit with higher number is preferred for changeover
- Manual front panel changeover selection

Technical Specifications

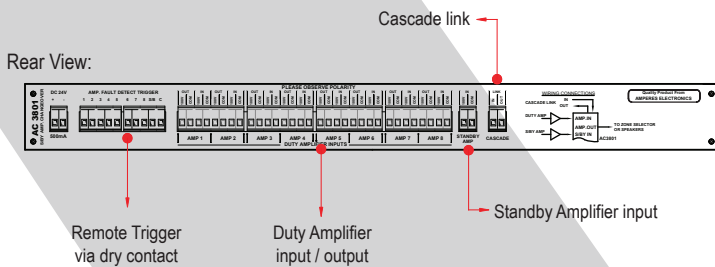

Operating voltage	24V DC ; 0.2A
Power consumption	Standby: 82mW, 3.4 mA Operating: 1.3W, 50 mA
Zone load rating	500W / 100V line input (max)
No of amplifier inputs	8 duty, 1 standby
Changeover indication	Front panel LED for duty amplifier being Changeover
Switching mode	Via front panel switches (manual mode) Remote trigger (auto mode)
Cable connections	Plug in detachable connectors with screw
Cascade capacity	Unlimited (Recommended 3)
Cable size	Up to 2.5 mm sq
Dimension (WxHxD)	482 x 44 x 180 mm
Weight	1.96 kg
Colour	Black, powder epoxy coated

Packing information

Qty per carton : 1 unit
 W x H x D : 552 x 93 x 294 mm
 Weight : 2.56 kg



AX3800 offers great flexibility and simplicity for amplifier fault changeover setup. With the precise circuit design, amplifier fault detection period is greatly reduced to initiate timely changeover to standby unit. The internal pilot tone generation at 20KHz is set at optimum interval to avoid unnecessary loading to amplifiers.

Changeover shall occur at both input and output of amplifiers, making it suitable for application in a matrix system. Priority and single changeover ensures overloading of standby amplifier is avoided, thus providing a reliable and uninterrupted system at most times.

Features

- Cater for 8 duty and 1 standby
- Expandable for 1 standby to cater for more than 8 duty amps.
- Built in Pilot Tone generator, transmit at intervals and senses at sequence to protect amplifiers
- Overloading protection by allowing only a single take over
- Prioritised changeover which higher numbered amplifier shall be preferred for take over if more than two units are down
- Shorter fault detection time from 7 to 15 seconds
- Changeover at input and output section simultaneously ; suitable for matrix system installations
- Input link switch ; making connection of sources easier
- Channel isolation switch for unused or un-monitored channel
- Individual channel status indicators ; normal, fault and changeover

Technical Specifications

Operating voltage	24V DC ; 1A
Power consumption	6.8 W
Input signal	8 Ch balanced line signal
Input impedance	10 K Ohm
Audio output gain	Unity
Pilot tone interval	8 seconds / channel
Pilot tone frequency	20 KHz (+/- 5%)
Detection line	70 / 100 V line
Detection level	50 V rms min
Failure detection time	7 - 15 seconds
Failure recovery time	20 seconds max
Zone load rating	500W / 100V line max
Status indication LED	Normal ; Fault ; Changeover
Changeover alert	Buzzer with switch
Changeover section	Input and output simultaneously
Dimensions (WxHxD)	482 x 88 x 180 mm
Weight	2.85 kg

Rear View:

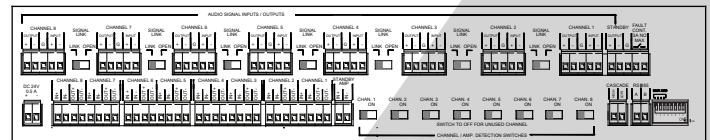

Application Schematic

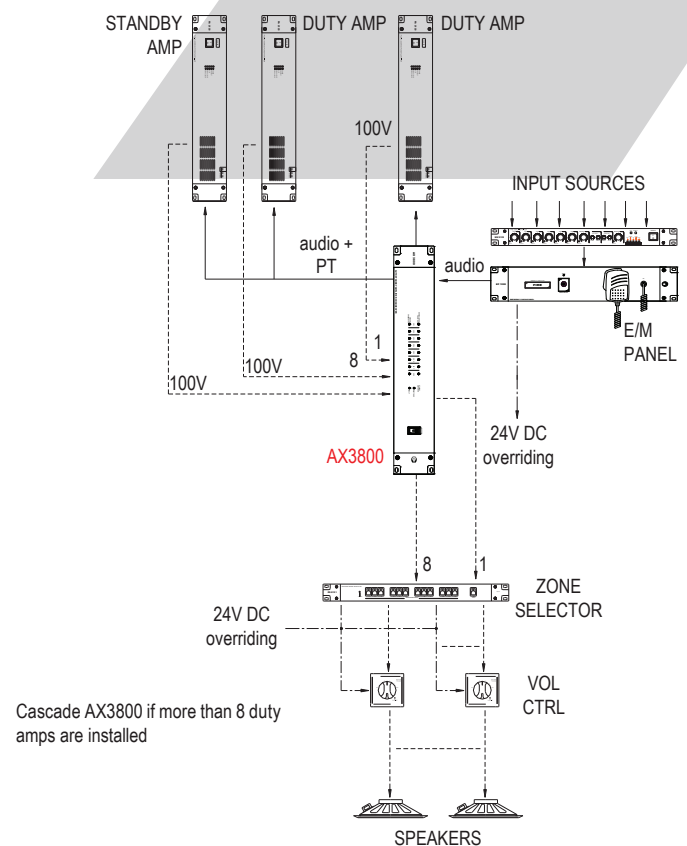

Packing information
 Qty per carton : 1 unit
 W x H x D : 552 x 163 x 294 mm
 Weight : 3.6 kg

LS4808 LS4816



8 / 16 CH SPEAKER LINE SURVEILLANCE

LS4808
8 Ch Line Surveillance



LS4816
16 Ch Line Surveillance



Introduction

Speaker line monitoring units from Amperes has been further enhanced with the introduction of these two totally new models. LS4808 is an 8 channels version while LS4816 is 16 channels.

With its new processor and measurement algorithm, they are now able to perform tasks faster with better accuracy than before. Setting up has also been much simplified for ease of installation. One distinct feature is external force activation, which if it is connected to a program timer, monitoring shall begin at preset times, thus avoiding disturbances to occupants of the building.

LS4800 series provides reliable speaker circuit monitoring for ground leakage, short and open circuit using impedance measurement method, thus eliminating the use of end line resistors in the speaker networks. With its RS485 data terminal, it can be connected to PMX LAN software via iPX5500 for remote monitoring.

Features

- 8 / 16 channel speaker line monitoring and expandable
- Basic and Advance level of detection setup
- Detection of faulty cable and speaker in individual zone or circuit
- Impedance measurement method - no capacitor coupling required and cable branching allowed.
- Faulty circuit disconnection option
- Built in impedance meter, range within 10 Ohm to 10 K Ohm
- LCD display to facilitate system setup, measurement and monitoring
- Fault alert with LED indicators and switchable buzzer
- Detection test interval setting from 1 min to 48 hours
- Short burst test signal, minimizing interruption to PA operation
- User setting for detection sensitivity for open, short and leakage
- Aux 24V DC output for volume controller overriding during testing mode

Technical Specifications

	LS4808	LS4816
Operating voltage	24V DC via PS9400 adaptor	
Power consumption	3.8W	4.9W
Capacity	8	16
Processor	STM 32 microprocessor	
Impedance detection range	10 to 10 K Ohm	
Power measurement range	10 to 1000W 100W 100V line	
Measurement accuracy	+/- 3% within range	
Pilot tone injection frequency	1 KHz	
Pilot tone signal output level	5V sine	
Monitor triggering	Auto / remote trigger	
Transmittal detection period	0.5 second per channel (max)	
Detection interval	User preset from 1 min to 48 hrs	
Sensitivity setting	User preset at each channel	
Indicators - LED	Normal, Fault, Buzzer, Auto run	
Display LCD	2 x 16 characters w back light	
Audible output signal	Continuous buzzer with Off option	
Dry contact setting	3A	
DC output in detection mode	24V DC for individual channel	
Dimensions (W x H x D)	482 x 44 x 180 mm	482 x 88 x 180 mm
Weight	2.4kg	3.1kg

Rear View LS4808:

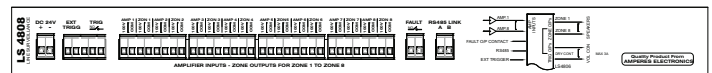

Rear View LS4816:

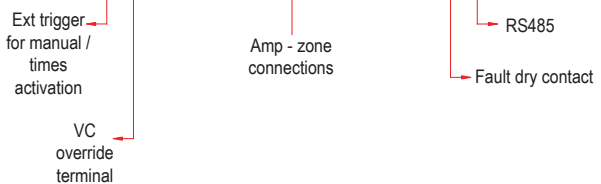
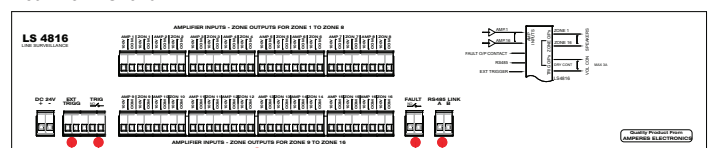

Packing information

Carton	: LS4808: 552 (W) x 93 (H) x 294 (D) mm
	: LS4816: 552 (W) x 163 (H) x 294 (D) mm
Weight	: LS4808 : 3.1 kg
	: LS4816 : 3.9 kg
Qty	: 1 unit / carton



AM4120 shall be used to monitor amplifier outputs of 70 / 100V line at the rack which is equipped with level meter, amplifier output LED and speaker for audio monitoring. It can also be used as a tool to calibrate sound output level of each amplifier from the rack.

Features

- 12 inputs for 70 / 100V line amplifier outputs
- Dual mode monitoring with continuous signal indicator
- Audio monitoring with volume control

Packing information

Qty per carton : 1 unit
 W x H x D : 552 x 93 x 294 mm
 Weight : 2.8 kg

Rear View:



Technical Specifications

Operating voltage	24V DC via PS9400 PSU
Power consumption	50 mW
Amplifier inputs	12 : 70 / 100V line
Monitoring mode	Audio : 1W speaker with 5 presets Visual : segment LED level meter LED for all channels
Dimensions (WxHxD)	482 x 44 x 180 mm
Weight	2.1 kg

Technical Specifications

Operating voltage	24V DC via PS9400 PSU
Power consumption	200 mW nominal
Input impedance	10 K balanced
Output impedance	600 Ohm balanced
Max audio input	0.75V
Max audio output	1.2V
Transmit interval	10 seconds
Detection delay	20 seconds
Recovery time	30 seconds
Frequency response	20 - 20 KHz
Detection output	NO and NC dry contact
Dimensions (WxHxD)	120 x 96 x 28 mm
Weight	330 gms

AS4000 | Amplifier Surveillance Module



AS4000 is used to monitor the status of 70 / 100V line power amplifiers which do not have built in detection module. Every amplifier shall employ one AS4000 and the dry contact output from the unit shall then be connected to Amperes AC3801. Repeating this link shall then form an automatic amplifier fault changeover / surveillance system.

Features

- Interval Pilot Tone injection ; reduces strain to amplifiers
- Works independently with or without availability of audio signal
- Low distortion to original audio signal
- Status monitoring via LED ; Pilot Tone and amplifier fault
- Compatible with most 70 / 100V line amplifiers in the market

These next generation of zone selectors are introduced to meet the new demands for a fail safe equipment. They are available in 6 and 12 zones and expandable for larger configurations.

ZS5602 / 5122 may look and function similarly with other zone selectors but they have several distinctive features for safety, operation and monitoring. All zone contacts shall automatically closed during power failure or damage to the unit, which is vital to continuous emergency broadcast. RS485 communication port is available for remote triggering or monitoring via PMX software.

ZS5062

6 Ch Speaker Zone Selector



ZS5122

12 Ch Speaker Zone Selector



Features

- Available in 6 and 12 zones ; expandable to 192 zones
- Fail safe zone trigger during power or unit failure
- Remote zone triggering via analogue and RS485 data
- Zone monitoring via PMX II software
- Local paging overriding bypassing BGM
- Flexible amplifier to zone configuration

Technical Specifications

	ZS5062	ZS5122
Operating voltage	24V DC via PS9400 adaptor	
Power consumption (idle)	3.29W	6.25W
Power consumption (All Call)	0.72W	0.96W
Current consumption (idle)	0.14A	0.26A
Current consumption (All Call)	0.03A	0.04A
Max load / channel	500W at 100V line	
Number of zones	6	12
Amplifier inputs	6	12
Zone selection	Front panel switch and remote	
Cascade limitation	16	
Remote triggering	-ve triggered (common ground)	
Indicators	Individual zone switch, Priority	
Data communication	RS485 19.2 kbps baud rate	
Switching mode	Individual, All Call Local zone selection bypassed when remote trigger is activated	
Dimensions (W x H x D)	482 x 44 x 180 mm	
Weight	1.85 kg	2 kg

Amp - Zone Outputs

Rear View ZS5062:



Rear View ZS5122:

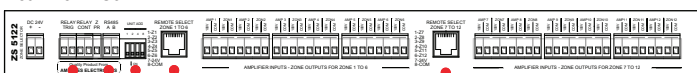

Packing information

- Carton : 552 (W) x 93 (H) x 294 (D) mm
- Weight : ZS5602 : 2.5 kg
- : ZS5122 : 2.7 kg
- Qty : 1 unit / carton

ZS5601 and 5121 are trusted product for speaker zone selection which had been used for more than a decade.

They provide direct zone switching for single source PA setup via front panel switches or through remote port connected to Amperes PM Series paging desk, or through Amperes TD decoders when PD series of paging desks are used. Other made of paging consoles are compatible with ZS provided they have negative triggering switching ports.

A distinctive feature shall be the remote override function which bypasses local zone selection whenever a paging mic connected to it is activated. The individual input and output connections make it flexible for amp-zone configurations as well as for matrix setup.

ZS5601

6 Ch Speaker Zone Selector



ZS5121

12 Ch Speaker Zone Selector



Features

- Available in 6 (ZS5601) and 12 zone (ZS5121) respectively with ALL CALL
- Expandable to more zones as required
- Remote zone triggering port via external paging microphone or console
- Paging override by Amperes paging console with Priority override indicator
- Emergency paging mic triggering port with dry contact for volume controller overriding application
- Flexible amplifier to zone configuration

Rear View:

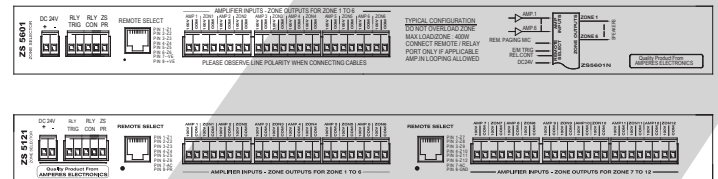

Application Schematic

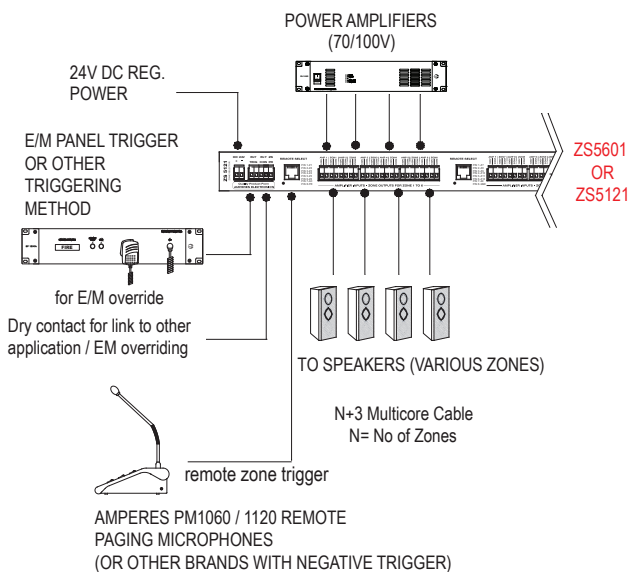

Technical Specifications

	ZS5601	ZS5121
Operating voltage	24V DC adaptor	
Power consumption	3.5W, 0.14A w All Call	6.8W, 0.28A w All Call
Max load / channel	500W at 100V line	
Number of zones	6	12
Amplifier inputs	6	12
Zone selection	Front panel switch and remote	
Cascade limitation	Unlimited	
Remote triggering	-ve triggered (common ground)	
Indicators	Individual zone switch, Priority	
Switching mode	Individual, All Call Local zone selection bypassed when remote trigger is activated	
Dimensions (W x H x D)	482 x 44 x 180 mm	
Weight	1.7 kg	2.1 kg

Packing information

Carton	: 552 (W) x 93 (H) x 294 (D) mm
Weight	: ZS5601 : 2.3 kg ZS5121 : 2.8 kg
Qty	: 1 unit / carton



ZS5602 shall be suitable for uninterrupted paging setup, i.e. when an announcement to a zone is made, other areas with BGM shall not be interrupted.

This shall require two sets of amplifiers connected to the ZS5602, thus the system shall consist of two sources, one being BGM and the other as Paging.

Similarly to ZS5601 / 5121, paging zone can be remotely triggered and each zone shall have separate amp input - zone output terminals, thus making it flexible for amp-zone configuration.

Rear View ZS5602:

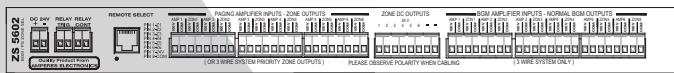

Technical Specifications

Operating voltage	24V DC ; 0.5A
Power consumption	10W ; 0.42A at ALL CALL
Insertion loss	0.5 dB max
Max load / channel	500W at 100V line
Number of zones	6
Amplifier inputs	6 BGM ; 6 Paging
Zone selection - BGM	Front panel switch
Zone selection - Paging	Front panel switch, remote
Indicators	Zone LED
Aux output voltage	24V DC ; 3A max / zone
Dimensions (WxHxD)	482 x 44 x 180 mm
Weight	2.2 kg

Features

- Available in 6 zones for BGM and 6 for Paging with ALL CALL
- Expandable or link multiple units to form more zones
- Remote zone triggering port via external paging mic
- Emergency paging mic triggering port with dry contact for volume controller overriding application
- Aux DC output for selected paging zone
- Suitable for 3 or 4 wire system

Application Schematic

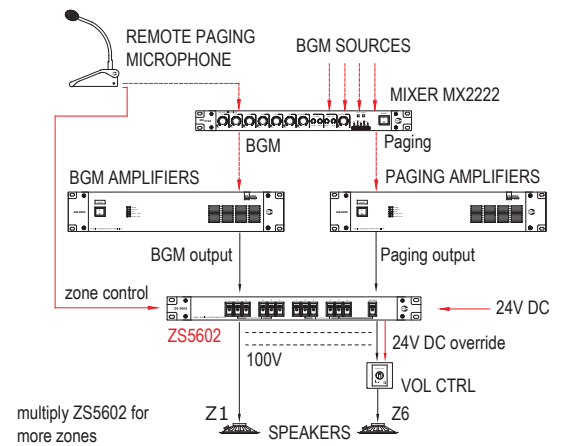

SS6401 | 4 Input BGM Source Selector

SS6401 has 4 BGM source input via RCA jack with mono output suitable for PA system. Its has line balancing circuitry which provide equal output level no matter which input is selected, as different BGM source has different output level. This avoids the trouble to adjust mixer volume whenever a different source is changed.



Technical Specifications

Input voltage	24V DC ; 0.3A
Consumption	0.15A
Input level / Imp (max input)	CD : 2V / 47 K Ohm Tuner : 600 mV / 10 K Ohm Cassette : 500 mV / 10 K Ohm Aux : 1.25V / 20 K Ohm
Input connection	RCA mono
Output	RCA mono, 1V 600 Ohm
Gain (max)	CD : -6 dB / Tuner : 4 dB Cassette : 6 dB / Aux : -2 dB
Selection	Daisy chain
Dimensions (WxHxD)	482 x 44 x 180 mm
Weight	1.8 kg

Features

- 4 input sources ; Cassette, CD, Tuner and Aux
- Input level balancing circuit for constant output level for different type of BGM source

Rear View SS6401:

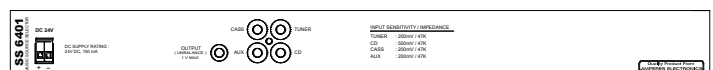

Packing information

Carton	: 552 (W) x 93 (H) x 294 (D) mm
Weight	: ZS5602 : 2.5 kg SS6401 : 2.9 kg
Qty	: 1 unit / carton

TD6080 is engineered for convenience, combining data decoder and zone selector in a box, which is translated into fewer component counts and cabling cost. It is also suitable for decentralised installations of multiple locations, which can communicate with central paging system through RS485 or LAN.

Features

- Integrated paging mic zone decoder and zone selector for simplified system interconnections
- Multipoint paging input from PD series of paging mics
- 8 input / 8 output configurable amp – speaker line connections
- Cascade feature for larger number of zones
- Configurable as group BGM / Paging for matrix setup

TD6080

8 Ch Decoder / Zone Selector



TD6240

24 Ch Data Decoder



TD6240 is an intermediary equipment between PD series of paging microphone and zone selectors. It accepts up to 3 mic input circuits ; enabling multipoint paging setup and has 24 analogue switching circuits to be connected to ZS series of zone selectors. More than one TD6240 can be stacked to achieve expanded zone quantity.

Technical Specifications

TD6080

Operating voltage	24V DC
Consumption	6W (250 mA)
Max load / channels	500W at 100V line
Cascade Quantity	16 Unit (128 zone)
Input circuits	2
Number of zones	8
Amplifier inputs	8
Zone selection	Front panel switch & remote
Indicators	Individual zone switch
Switch mode	Individual, All Call Local zone selection bypassed when remote trigger is activated

AUDIO

Input impedance (Ohm)	Line : 10 K
Output impedance	600 Ohm balanced
Freq response	70 ~ 15 KHz
Audio input	Line
Max audio output	Line 1.2V

DATA

Data protocol	RS485
Baud rate	19.2 K bps
Dimension (WxHxD)	482 x 44 x 180 mm
Weight	2 kg

Rear View TD6080:



Rear View TD6240:

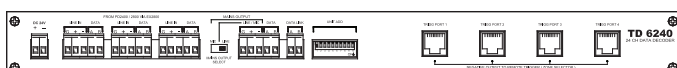

Features

- Expandable and addressable to cater for more than 24 zones
- Priority setting for multi point paging setup
- Selectable balanced audio output level (mic or line)
- Compatible with most zone selectors with remote triggering port
- Connects directly to ZS5601 / 5121 via remote triggering port using RJ45 connector

TD6240

Operating voltage	24V DC
Consumption	2.4W (100 mA)
Switching channels	24
Cascade / max zones	8 (max 192 zones)

Input circuit	3
Output connection (Triggering)	RJ45 to ZS zone selector

AUDIO

Input impedance (Ohm)	Line : 10 K
Output impedance	600 Ohm balanced
Freq response	70 ~ 15 KHz
Audio input	Line
Max audio output	Line 1.2V

DATA

Data protocol	RS485
Baud rate	19.2 K bps
Dimension (WxHxD)	482 x 44 x 180 mm
Weight	2.5 kg

Packing information :

Carton : 552 (W) x 93 (H) x 294 (D) mm
Weight : 2.5 kg
Qty : 1 unit / carton

Carton : 552 (W) x 93 (H) x 294 (D) mm
Weight : 3.2 kg
Qty : 1 unit / carton



Meet the all new next generation of innovative Battery Charger, which has been engineered to meet the requirement of installers and users alike. It is compact in 1 HU height, built with the latest technology for efficient charging, controls and monitoring purpose.

Driven by powerful ARM processor, it works to protect against misconnections, prolonging battery life with its battery monitoring feature and communicates to provide human interaction. RS485 data port is available for external monitoring via PMX II Software and can be readily linked up to LAN through iPX5500 Com Box.

Amperes invites you to experience this innovative product which we had meticulously developed for the convenience of the valued users.

Features

- Constant DC voltage charging for 24V battery bank
- 4A initial charging current with reducing rate over charging time
- Built in surge protection
- Output short circuit protection
- Thermal protection against overheating
- Auto low battery disconnection with LCD indication
- Battery reversed polarity protection
- Rear mains switch to avoid unnecessary switching off the unit
- RS485 communication for remote monitoring via PMX II software

Technical Specifications

Operating voltage	220 - 240V AC
Charging voltage	28.8V DC
Charging current	4A; (max 5A)
Idle power consumption	1.3W
Protections	Low battery auto disconnection, reverse polarity, standby protection
Indications	AC mains, short circuit and low battery
Displays	Charging current Charging voltage Battery voltage Output current Battery reverse polarity
Communication	RS485 out; link to Amperes PMX II LAN via iPX5500 comm. box for remote monitoring
E/M back up Amp rating	25A max (Use external contactor / relay if required)
Terminals	Battery input , EM load
Dimensions (WxHxD)	482 x 44 x 180 mm
Weight	4.15 kg

Rear View:

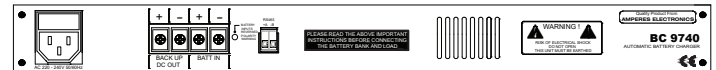

Application Schematic

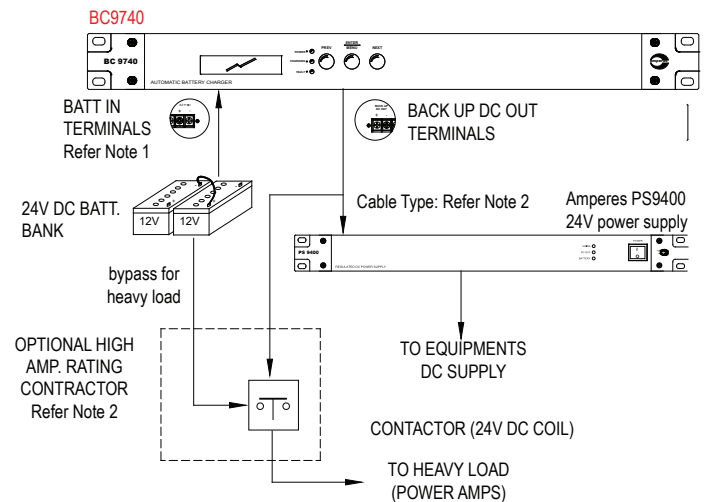

Packing information
 Qty per carton : 1 unit
 W x H x D : 552 x 93 x 294 mm
 Weight : 4.90 kg



Features

- 8 channel with 6A per channel; total load of 15A with surge protection
- Cascade 2 units to form 16 channel setup
- ON / OFF sequential switching
- Remote switching port via external noiseless contact
- AC output via IEC connectors with channel isolation via DIP switch
- Ch. 8 with delay Off option for 2 min ; suitable for video projector connection
- Lock mode to avoid incidental switching

SQ9815 is suitable for applications in PA, sound and AV system in which it manages the powering sequence of every equipment in orderly manner. It works to provide a some degree of protection to the lifespan of the equipment as random powering may cause irreversible damage.

It has internal surge protection to kill harmful incoming power spikes. An important tool that works to safely powering up your equipment with a touch of a button.

Rear View:

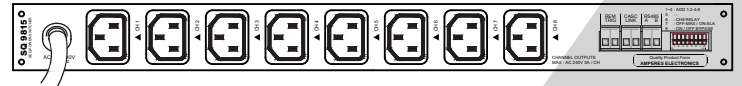

Technical Specifications

Operating voltage	220 - 240V AC
Power consumption	50 mW (without load)
Output voltage	230 / 240V AC
Max load / channel	6A
Max total load	15A
Output connection	IEC female socket
Max cascade	2 uts : total 16 channels
Surge protection	L-N, L-E, N-E.
Clamping voltage	870V AC
Turn on sequence	Step 1 to 8 incremental
Turn off sequence	Step 8 to 1 decremental
Step timing	2 seconds
Delay off option	Channel 8 via DIP switch
Delay off timer	2 minutes
Switch lock	Via front switch
Indicators	AC mains, Ch. on, Lock
Dimensions (WxHxD)	482 x 44 x 180 mm
Weight	2.82 kg excl. accessories

Packing information

Qty per carton	: 1 unit
W x H x D	: 552 x 93 x 294 mm
Weight	: 3.5 kg

Regulated 24V DC Power Supply | PS9400



Technical Specifications

Operating voltage	220 - 240V AC
Output voltage	24V +/- 1%
Rating	4A nominal ; max 4.5A
No load consumption	50 mW
Efficiency	83%
Indicators	AC mains, battery input, DC output
Protections	Built in surge protection Short circuit Overload (105% ~ 150%) Over voltage (115% ~ 135%)
Output DC protection	Fuse
Terminals	Batt input and load ; barrier connector
Dimensions (WxHxD)	482 x 44 x 180 mm
Weight	2.6 kg

PS9400 is a rack mounted 24V DC regulated power pack designed uniquely for PA installations. It comes with built in changeover relay which shall be connected to back up 24V DC to allow continuous and uninterrupted supply to the whole installation whenever the mains failed.

Features

- 4V DC 4A output highly regulated switching power supply
- Output circuit breaker protection
- Built in surge and short circuit protection
- Back up battery overriding relay

Rear View:



Packing information

Qty per carton	: 1 unit
W x H x D	: 552 x 93 x 294 mm
Weight	: 3.3 kg



VR7600 - Rack Mounted Zone Volume Controllers

VR series is available in three variants with 6 zones at each panel, to be mounted at rack to enable volume of each zone to be controlled or set at the control room.

Features

- 6 zones with 50 / 100 / 150W 100V line rating for each zone
- Customised zone rating option available
- Suitable for 4 wire system : 2 for 100V audio & 2 for 24V DC overriding
- Built in overriding relay for emergency volume bypass

Technical Specifications

VR7605 / VR7610 / VR7615	
Power rating	50 / 100 / 150W 100V line / zone
Overriding voltage	24V DC
Overriding current	15 mA per channel
Attenuation	6 steps incl. OFF
Attenuation / step	6 dB / step
Attenuation method	Auto transformer
Size (W x H x D)	482 x 88 x 60 mm
Weight	2.1 / 3.1 / 3.2 kg

Application Schematic

VR should be installed before LS4600 to avoid false fault detection due to variation of impedance whenever volume is adjusted.

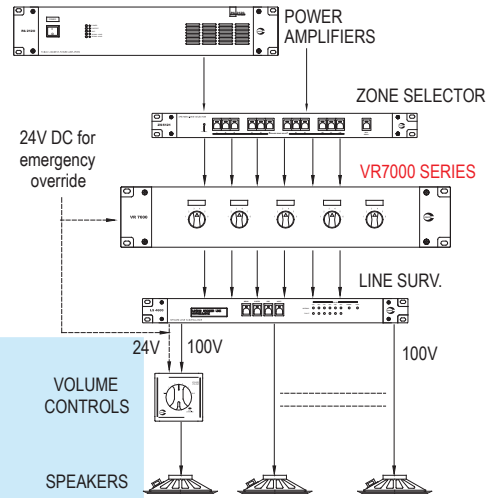

AV7200 | 100W 100V Line Auto Volume Controller



AV7200 is used for controlling speaker volume automatically for a localised area by adjusting the 100V line audio according to the ambient noise. As it varies the volume at 100V instead of sending control signal to the system, it can be easily applied to the existing systems without having to lay new cabling or installing new equipment.

Among suitable areas are shopping malls, stations, building lobbies, etc.

- Installation at localised area (at existing volume controller) without additional cable re-run (easily retrofit to existing system)
- 100V speaker line control with 6 step attenuation
- Adjustable noise sensing sensitivity
- Built in overriding relay for emergency volume bypass

Application Schematic

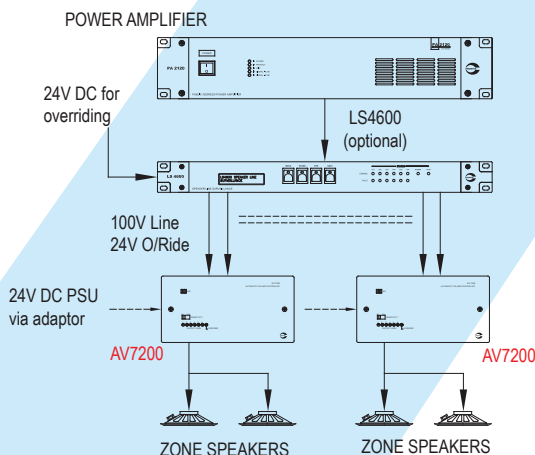

Technical Specifications

Power rating	100W 100V line
Operating voltage	24V DC : 40 mA
Attenuation	6 steps ; -6 dB per step
Emergency overriding	24V DC ; 0.15A
Sensitivity adjustment	2 level
Dimension (W x H x D)	247 x 87 x 50 mm
Weight (excl. enclosure)	1.1 kg

SPEAKER VOLUME CONTROLLERS

VC7000
VC8000

From contemporary to classic design, Amperes offers choices for different installation needs. The variants are in three different designs and available in various ratings, ranging from 5 watts to 150 watts 100V line.

They are suitable for 4 wire system installation with built in emergency overriding relay and overriding LED indicator.



VC7000 - 5 - 150W 100V (86 x 86 mm)

Features

- Suitable for 4 wire system : 2 for 100V line , 2 for 24V DC overriding signal
- Built in overriding relay to allow emergency signal to bypass volume attenuation
- Overriding LED indicator whenever EM paging is activated
- 5 preset attenuation with OFF
- Large cable terminal block for ease of termination



VC8000 - 5 - 100W 100V (86 x 86 mm)



VC7000A - 5 - 100W 100V (70 x 120 mm)

For 70 x 120 faceplate series:
Vertical and Horizontal version available

Technical Specifications

Power rating	Refer to variants
Overriding voltage	24V DC
Overriding current	15 mA per channel
Attenuation	6 steps incl. OFF
Attenuation / step	6 dB / step
Attenuation method	VC7005 / 7010 / 8010 - Resistive Others - Auto transformer
Colour	White
Size (W x H x D)	VC7000 / 8000 - 86 x 86 x 40 mm VC7000A - 70 x 120 x 40 mm
Weight	VC7805 / 7005 / 7010 - 100 gms
	VC7030 / 7050 - 248 gms
	VC7100 / 7150 - 382 gms
	VC8010 - 250 gms
	VC8030 - 254 gms
	VC8050 - 264 gms
	VC8100 - 269 gms

Optional item :

Conceal enclosure	77 x 77 x 60 mm
Surface enclosure	85 x 85 x 60 mm

Application Schematic

4 wire system installation

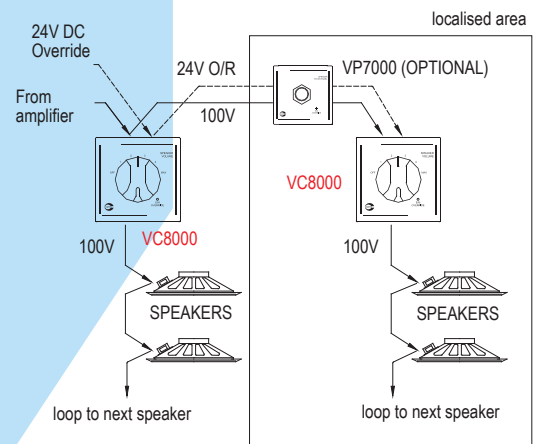

Variants :

VC8000 SERIES (86 X 86 mm)

VC8010 :	10W 100V Line Resistive
VC8030 :	30W 100V Line Auto Trans
VC8050 :	50W 100V Line Auto Trans
VC8100 :	100W 100V Line Auto Trans

VC7000 SERIES (86 x 86 mm)

VC7810 :	10W 8 OHM Resistive
VC7005 :	5W 100V Line Resistive
VC7010 :	10W 100V Line Resistive
VC7030 :	30W 100V Line Auto Trans
VC7050 :	50W 100V Line Auto Trans
VC7100 :	100W 100V Line Auto Trans
VC7150 :	150W 100V Line Auto Trans

VC7000A SERIES (70 X 120 mm)

VC7010A :	10W 100V Line Resistive
VC7030A :	30W 100V Line Auto Trans
VC7050A :	50W 100V Line Auto Trans
VC7100A :	100W 100V Line Auto Trans

NOTE :

Wall concealed installation shall require back enclosure with depth of min 50 mm from finishing surface for models with auto transformer. Normal electrical back enclosure shall suffice for installation using resistive volume controllers. ie. VC7005 / 7010 / 8010





VP7501 - Local Speaker Patch Panel



VP7810 - 8 Ohm Speaker Patch

Introduction

VP7501 is used to isolate a group of speakers (meeting room, etc) from central PA system to allow a separate PA amplifier to utilise those local speakers, but can be overridden by main system when a 24V overriding signal is present.

VP7810 works similarly but the local speaker is 8 Ohm, ie. setup in hotel room with speaker connected to TV audio output via a mini amplifier. In the event of emergency, it shall allow the incoming 100V line to take over and to match the speaker's impedance.

Features

- Suitable for 4 wire system : 2 x audio, 2 x 24V DC overriding
- Built in overriding relay for emergency bypass with LED indicator
- Also available with 70 x 120 mm front panel

Application Schematic

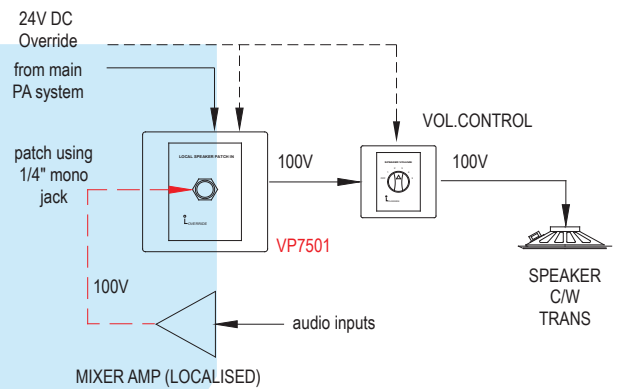

VP7501 application schematic

Technical Specifications

	VP7501	VP7810
Power rating	50W 100V line	10W 8 Ohm
Overriding voltage	24V DC : 15 mA	
Patch connection	1/4" phone jack-front patch	Hardwired
Cablings	4 wire system (2 audio ; 2 overriding)	
Size (front panel)	86 x 86 mm	
	70 x 120 mm face plate available upon request	
Weight (excl. enclosure)	69 / 215 gms	
Concealed (W x H x D)	77 x 77 x 60 mm	
Surface (W x H x D)	85 x 85 x 60 mm	

Packing information

Carton (W x H x D) : VP7501 / VP7810 : 550 x 220 x 420 mm
 Weight : VP7501 : 200 g per unit
 : VP7810 : 300 g per unit
 Qty : VP7501 / VP7810 : 90 uts per carton

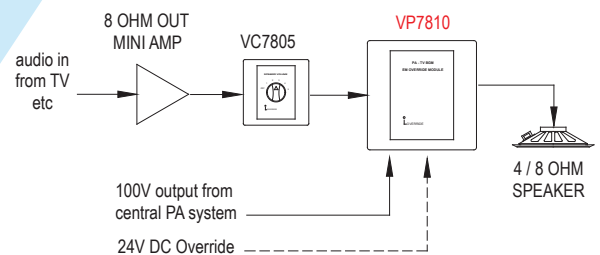

VP7810 application schematic

2"/5"/6"

6W 100V LINE CEILING SPEAKER

CS210
CS510
CS210





Introducing a newly designed ceiling speakers, CS210, 510 and 610 which break away from the normal outlooks and are now portrayed as cosy with its slim edge baffle.

Three variants are available with re-engineered sound output to serve the needs for both BGM and EVAC. CS210 is a miniature version most suitable for small enclosed area such as hotel room foyer and narrow corridors, while CS510 and 610 fits most other installations according to the needs of different coverage areas.

**NEW DESIGN,
CONTEMPORARY
OUTLOOK**



Features

-  Slim edge design with low side profile
-  High quality ABS enclosure with optional FR grade
-  Spring clip installation
-  Option for installation without enclosure

Packing information

CS210 : 230(W) x 275(H) x 570(D) mm
: 11.30 kg
: 20 uts per carton

CS510 : 360(W) x 400(H) x 710(D) mm
: 22.70 kg
: 24 uts per carton

CS610 : 440(W) x 430(H) x 660(D) mm
: 19.20 kg
: 18 uts per carton

Technical Specifications

	CS210	CS510	CS610	CS610B
SPEAKER				
Power rating	6W 100V line			10W 100V line
Diameter	2" (51 mm)	5" (125 mm)	6" (150 mm)	
Cone type	Single cone	Dual cone		
Impedance (Ohm)	8			
Freq response @ 1KHz +/-3 dB	160 - 15 KHz	150 - 19 KHz	120 - 19 KHz	
SPL @ 1W / m (+/- 3dB) 1 KHz)	90 dB		92 dB	
TRANSFORMER				
Tapping (100V line)	1.5 / 3 / 6W			1 / 3 / 6 / 10W
Primary impedance (Ohm)	6.7K / 3.3K / 1.67K			10K / 3.3K / 1.67K / 1K
Secondary impedance (Ohm)	8			
PHYSICAL				
Grille / enclosure	Metal / ABS enclosure			
Cutting hole dim	85 mm	145 mm	185 mm	
Overall size (dia x height)	110 x 110 mm	165 x 110 mm	205 x 110 mm	
Weight	500 g	740 g	840 g	850 g
Colour	White			



CS343 : WEATHERPROOF CEILING SPEAKER

CS343 is driven by a 4" dual cone speaker with built in matching transformer of dual taps of 3 and 6W 100V line.

Made of quality ABS enclosure and aluminum grille, it is suitable for high humidity areas, such as bathrooms and salty environment. Though compact in size, it delivers satisfactory sound reproduction with high SPL level, good for listening pleasure as well as paging clarity.

Packing information

CS343 : 370 (W) x 600 (H) x 370 (D) mm
 : 17.5 kg
 : 16 uts per carton



CS343 - 4" 6W 100V Line



CS515 - 5" 6W 100V Line

CS515 : DUAL CONE CEILING SPEAKER W ABS ENCLOSURE

CS515 is a general purpose 5" 6W 100V line ceiling speakers which comes complete with ABS honeycomb grille and back enclosure. It is suitable for BGM and Paging application and also for rust prove environment. Fire Retardant Enclosure available as CS515FR.

Packing information

CS515 : 850 (W) x 385 (H) x 240 (D) mm
 : 12 kg
 : 16 uts per carton

CS606 : DUAL CONE CEILING SPEAKER W METAL ENCLOSURE

Available in 6" dual cone speaker with back metal enclosure, grill and baffle and multi tap matching transformer of 1.5, 3 and 6W 100V line. This model shall be suitable for installations that demand fire resistant version of dome.

Packing information

CS606 : 509 (W) x 310 (H) x 400 (D) mm
 : 14 kg
 : 20 uts per carton



CS606 - 6" 6W 100V Line

Technical Specifications

	CS606	CS515	CS343
SPEAKER			
Power rating	6W 100V line nominal (max 10W)		
Diameter	6" (150 mm)	5" (125 mm)	4" (100 mm)
Cone type	Dual cone		
Impedance (Ohm)	8		
Freq response @ 1KHz +/-3dB	150 ~ 16 KHz	150 ~ 17 KHz	150 - 18 KHz
SPL @ 1W / m (+/- 3dB) 1 KHz	91 dB	92 dB	90 dB
TRANSFORMER			
Tapping (100V line)	1.5 / 3 / 6W		3 / 6W
Primary impedance (Ohm)	6.7K / 3.3K / 1.67K		3.3K / 1.67 K
Secondary impedance (Ohm)	8		
PHYSICAL			
Grille / enclosure	Mild steel	ABS Plastic	Aluminum / ABS
Cutting hole dim	165 mm	145 mm	120 mm
Overall size (dia x height)	200 x 70 mm	175 x 95 mm	140 x 130 mm
Weight	660 g	600 g	1 kg
Colour		White	



**CS620 / CS840**

6" / 8" 20 / 40W 100V Line

**CS518**

5" 20W 100V Line

CS620 / 840 : CO-AXIAL CEILING SPEAKER

CS620 and 840 meets the requirement of hi fidelity of sound reproduction in areas such as function halls, restaurants and also for sound reinforcement at banquet halls. They are available in 6" and 8" version of speaker driver with tweeter and 100V line matching transformer.

Packing information

CS620 : 740(W) x 545 (H) x 275 (D) mm
: 22.7 kg
: 8 uts per carton

CS840 : 740 (W) x 630 (H) x 340 (D) mm
: 21 kg
: 8 uts per carton

CS518 : SQUARE CO-AXIAL CEILING SPEAKER

CS518 matches other fittings at ceiling where most of them are in square or rectangular shapes. It's size is almost similar to square shape light fittings and is loaded with co-axial 5" driver, delivering clear and crispy sound. It is suitable for boutiques, residence, offices as well as lobbies.

Packing information

CS518 : 580(W) x 510 (H) x 310 (D) mm
: 17.1 kg
: 7 uts per carton

Technical Specifications

	CS620	CS840	CS518
SPEAKER			
Power rating	20W 100V	40W 100V	20W 100V
Diameter	6.5" (165 mm)	8" (200 mm)	5" (125 mm)
Cone type	Co-axial		
Impedance	8 Ohm		
Freq response @ 1KHz +/- 3dB	80 ~ 18 KHz	90 ~ 19 KHz	100 ~ 18 KHz
SPL @ 1W / m (+/- 3dB) 1 KHz	88 dB	90 dB	85 dB
	10 oz	15 oz	10 oz
TRANSFORMER			
Tapping (100V line)	20W	40W	2.5 / 5 / 10 / 20W
Primary impedance (Ohm)	500	250	4K / 2K / 1K / 500
Secondary impedance (Ohm)	8		
PHYSICAL			
Grille / enclosure	White metal / ABS white		
Cutting hole dim	205 mm	240 mm	150 x 150 mm
Overall size (dia x height)	240 x 145 mm	280 x 145 mm	180 x 180 x 135 mm
Weight	2.4 kg	2.1 kg	1.8 kg
Colour	White		

BS410 : SURFACE MOUNT SPEAKER

It is constructed with high quality ABS plastic with 4" dual cone speaker driver and multi tapping matching transformer of 1 / 3 / 6 and 10W 100 V line. Suitable for wall and ceiling installation with optional tilt mounting bracket. Available in white colour.

Packing information

BS410 : 550 (W) x 220 (H) x 420 (D) mm
: 12.5 kg
: 12 uts per carton

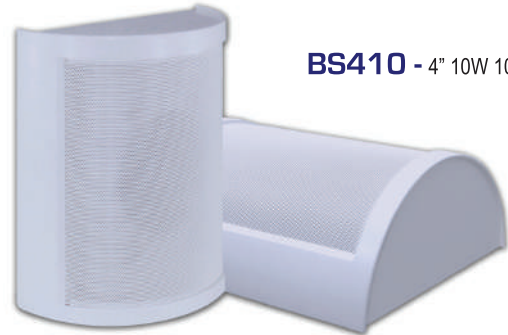

BS410 - 4" 10W 100V



DV410 - 4" 6W 100V

DV410 : SURFACE MOUNT SPEAKER

A classic yet favourite model which is suitable for installations in small enclosed areas such as staircase, office, etc. Available in white colour with multi tap matching transformer of 1 / 3 / and 6W 100V line, fit for vertical or horizontal installations.

Packing information

DV410 : 466 (W) x 406 (H) x 402 (D) mm
: 15 kg
: 20 uts per carton

BS506 : SURFACE MOUNT SPEAKER

Need not worry about rust with BS506 which is built from high quality ABS material. It delivers satisfactory sound reproduction with its 5" driver.

Packing information

BS410 : 550 (W) x 170 (H) x 395 (D) mm
: 11.2 kg
: 12 uts per carton



BS506 - 5" 6W 100V

Technical Specifications

	BS410	DV410	BS506
SPEAKER			
Power rating	10W 100V	6W 100V	6W 100V
Diameter	4"		5"
Cone type	Dual Cone		
Impedance (Ohm)	8		
Freq response @1KHz +/- 3dB	100 ~ 16 KHz	100 ~ 18 KHz	100 ~ 15 KHz
SPL @ 1W / m (+/- 3dB) 1 KHz	92 dB	90 dB	93 dB
TRANSFORMER			
Tapping (100V line)	1 / 3 / 6 / 10W	1 / 3 / 6W	
Primary impedance (Ohm)	10 K / 3.3 K / 1.6 K / 1K	10K / 3.3K / 1.6K	
Secondary impedance (Ohm)	8		
PHYSICAL			
Grille / enclosure	ABS with metal grille		ABS
Overall size (WxHxD)	185 x 205 x 90 mm	195 x 215 105 mm	172 x 195 x 105 mm
Weight	1 kg	0.75 kg	
Colour	White		

4"/5"

20W & 40W 100V LINE FULL RANGE SPEAKER

FS420

FS640

FS340

FS338

FS420 & FS640 : FOREGROUND MUSIC SPEAKER

Available in 4" and 6" of driver size complete with matching transformer, selectable power switch and mounting bracket. They are suitable for foreground soft music such as restaurants, shops and general sound reinforcement in meeting room, corridors, etc.

Packing information

FS420 : 440 (W) x 370 (H) x 250 (D) mm
: 9.65 kg
: 4 uts per carton

FS640 : 416 (W) x 355 (H) x 220 (D) mm
: 7.80 kg
: 2 uts per carton

FS338 : FOREGROUND MUSIC SPEAKER

FS338 is built as multi purpose speaker, optimising the features of smooth and pleasant outlooks while maintaining the audio performance. Thus by its appearance and sound quality, it can be employed in most indoor venues.

It is driven by 2 x 4" PP speakers and a 1" tweeter with 40W 100V line power. It can also be driven directly from audio amplifier with 4 Ohm connections. Multiple power tapping is available via the rotary switch from 5 to 40W 100V line.

Installation is rather flexible due to its dual angle mounting bracket. They can be mounted in horizontal or vertical position. If wider coverage is required, then can be installed in horizontal array format, with two, three or 360 degree format via the optional mounting pole.

Packing information

FS338 : 560 (W) x 295 (H) x 165 (D) mm
: 7.6 kg
: 2 uts per carton

FS340 : FOREGROUND MUSIC SPEAKER

FS340 delivers smoothing sound with its 6" driver with tweeter. Available in 40W 100V line with power selector for level adjustment to suit area of installation. It can be installed vertically or horizontally, thanks to its flexible mounting bracket.

Be it a restaurant, pub or cafe, meeting room or lobby, FS340 shall be the exact candidate to choose from.

Packing information

FS340 : 455 (W) x 385 (H) x 240 (D) mm
: 7.8 kg
: 2 uts per carton



FS420
(Black / White)

4" 20W 100V



FS640
(Black / White)

6" 40W 100V



FS340
6" 40W 100V



FS338
2 x 4" 40W 100V

Technical Specifications

	FS420	FS640	FS340	FS338
SPEAKER				
Power rating	20W 100V		40W 100V	
Diameter	4" (100 mm)	6" (150 mm)	6" (150 mm)	2 x 4" (100 mm)
Speaker type	2 way speaker with tweeter			
Impedance (Ohm)	8			
Freq response @ 1KHz +/- 3dB	100 ~ 18 KHz	70 ~ 18 KHz	70 ~ 16 KHz	
SPL @ 1W / m (+/- 3dB) 1 KHz	89 dB	88 dB		87 dB
TRANSFORMER				
Tapping (100V line)	1.25 / 2.5 / 5 / 10 / 20W	2.5 / 5 / 10 / 20 / 40W	5 / 10 / 20 / 40W	5 / 10 / 20 / 40W
Primary impedance (Ohm)	8K / 4K / 2K / 1K / 500 / 8	4K / 2K / 1K / 500 / 250 / 8	2K / 1K / 500 / 250 / 8	2K / 1K / 500 / 250 / 4
Secondary impedance (Ohm)	8			4
PHYSICAL				
Grille / enclosure	ABS enclosure with metal grille			
Overall size (WxHxD)	170 x 215 x 150 mm	215 x 284 x 190 mm	209 x 585 x 195 mm	137 x 385 x 262 mm
Weight (kg)	2.2	3.5	3.3	3.4
Colour	White and Black		Black	



Built ruggedly with aluminum die extrusion housing and available in 3 power rating of 10 / 20 / 40 and 60W 100V line with dual power tapping. Suitable for classrooms, hyper markets, mosques, ballroom, factories, passenger terminals, exhibition areas etc.



Features

- Slim design to match environment or hidden from view
- Engineered for speech and BGM clarity

Packing information

CL902	: 230(W) x 150(H) x 230(D) mm : 2.6 kg : 2 uts per carton
CL904	: 390(W) x 150(H) x 230(D) mm : 3.60 kg : 2 uts per carton
CL908	: 608(W) x 168(H) x 235(D) mm : 5.55 kg : 2 uts per carton
CL912	: 828(W) x 168(H) x 235(D) mm : 7.80 kg : 2 uts per carton

Technical Specifications

	CL902	CL904	CL908	CL912
Power rating	10W 100V	20W 100V	40W 100V	60W 100V
Speaker components	2 x 2"	4 x 2"	8 x 2"	12 x 2"
Transformer tapping(100V)	6 / 10W	10 / 20W	30 / 40W	50 / 60W
Primary impedance (Ohm)	1.6K / 1K	1K / 500	330 / 250	200 / 166
SPL descriptions	87 ± 3dB		88 ± 3dB	89 ± 3dB
Frequency response	230 - 16 KHz @ 1KHz +/-3dB			
Dimension (WxHxD) (mm)	190 x 79 x 89	350 x 79 x 89	567 x 79 x 89	782 x 79 x 89
Material	Aluminum			
Weight with bracket (kg)	0.9	1.4	2.35	3.2

20 - 40W 100V Line Column Speaker | CH700

Built ruggedly with aluminum die cast housing and available in 3 power rating of 20 / 30 and 40W 100V line with dual power tapping. Suitable for classrooms, hyper markets, mosques, etc.

Technical Specifications

	CH720	CH730	CH740
Power rating	20W 100V	30W 100V	40W 100V
Speaker component	2 x 4"	3 x 4"	4 x 4"
Tapping (100V line)	10 / 20W	15 / 30W	20 / 40W
Primary impedance (Ohm)	1 K / 500	660 / 330	500 / 230
Secondary impedance (Ohm)	8		
Freq response (+/- 3dB)	85 ~ 15 KHz	80 ~ 15 KHz	75 ~ 15 KHz
SPL @ 1W / m (+/- 3dB) 1 KHz	91 dB	93 dB	95 dB
Grille / enclosure	Aluminum / metal grille		
Overall size (WxHxD) (mm)	145 x 400 x 100	145 x 495 x 100	145 x 605 x 100
Weight (kg)	3.2	3.7	4.6
Colour	Dark grey / front black grille		



Packing information

CH720	: 430 (W) x 310 (H) x 220 (D) mm : 7.1 kg : 2 uts per carton
CH730	: 520 (W) x 320(H) x 215 (D) mm : 8.9 kg : 2 uts per carton
CH740	: 620 (W) x 310 (H) x 220 (D) mm : 10.5 kg : 2 uts per carton



PS820 : PENDANT BALL SPEAKER

Installations for high ceiling areas without columns, such as warehouses, hypermarkets and large showrooms that require even sound distributions shall select PS820 pendant ball speakers. It is built with 8" speaker of 20W 100V rating, delivering powerful and evenly projected sound with 180° dispersion.

Packing information

PS820 : 310(W) x 310(H) x 300(D) mm
: 3 kg
: 1 unit per carton

SG320 : OUTDOOR GARDEN SPEAKER

SG320 is the preferred choice for outdoor installations in parks, pool sides, etc, providing excellent music for listening pleasure. With its green outlooks, it blends perfectly to the shrubs, or hidden by leaves or grass. Thereby, its the right candidate to hide the sound source unlike the bulky speakers suspended at poles which may affect the aesthetic value of the environment.

Dual purpose

It is installed for paging purposes or to provide smooth music at outdoor installations.

360 dispersion

It provides an even dispersion of 360. An advantage over conventional speakers that may require at least 3 units for such an angle of coverage. Thus reducing the speaker count.

Powerful sound

Available in 20W 100V line input, SG320 shall deliver the punch of sound, smoothness of listening pleasure and clarity of voice announcement.

Built for all environment

High quality materials are used in the construction of the enclosure, which enable the unit to withstand outdoor environment - rain or shine.

Packing information

SG320 : 345(W) x 390(H) x 345(D) mm
: 4.65 kg
: 1 unit per carton



PS820
20W 100V Line



SG320
20W 100V Line
IP65

Technical Specifications

	PS820	SG320
Power rating	20W 100V line	20W 100V line
Power tapping (100V line)	5 / 10 / 20W	10 / 20W
Speaker diameter	8" (200 mm)	5" (125 mm)
Speaker type	Co-axial	
Primary impedance (Ohm)	2K / 1K / 500	1K / 500
Frequency response @ 1KHz +/- 3dB	80 - 18 KHz	70Hz - 16 KHz
SPL (1w/m @ 1 kHz)	91 dB	84 dB
Construction material	ABS	
Colour	White	Green
Dimensions	254 diameter (mm)	320 dia x 360 height (mm)
Weight	2.2 kg	3.6kg



SP219
SP319
SP220
HS725
HS750

PROJECTION / CLEAR HORN SPEAKERS



SP219 : 10W 100V LINE

SP219 : UNIDIRECTIONAL SOUND PROJECTOR

SP219 is used when a more directional sound projection is required for areas such as at narrow corridors, tunnels, walkways, etc. It has aluminum body with metal grille and available with standard power rating of 10W 100V line. Mounting position can be either at wall or hanged from ceiling.

Packing information

SP219 : 370 (W) x 600 (H) x 370 (D) mm
 : 18 kg
 : 8 uts per carton



SP319 : 10W 100V LINE BIDIRECTIONAL

SP319 : BIDIRECTIONAL SOUND PROJECTOR

It is suitable for narrow corridors, or walkways that requires sound reproduction in two direction. Installing bi directional speakers may reduce the speaker counts and thus lowering installation and cabling costs.

Packing information

SP319 : 370 (W) x 600 (H) x 370 (D) mm
 : 25 kg
 : 8 uts per carton



**SP220 : 20W 100V LINE
 IP65**

SP220 : UNIDIRECTIONAL ABS SOUND PROJECTOR

A more cost effective with higher power rating sound projector SP220 is 20W version built using ABS plastic for its body with metal grille.

HS725 : WEATHERPROOF CLEAR HORN SPEAKER

HS725 meets the requirement of speakers with horn characteristics and yet delivers sound with music clarity.

It is suitable for installations in almost any areas particularly outdoors, able to withstand rain and shine.

Packing information

HS725 : 440 (W) x 250 (H) x 370 (D) mm
 : 4.9 kg
 : 1 unit per box



**HS725 : 30W 100V LINE
 IP54**

HS750 : WEATHERPROOF HORN SPEAKER

HS750 is a powerful clear horn suitable for outdoor and indoor applications.

Among suitable venues are stadiums, theme parks, beaches for early warning system and also car parks.



**HS750 : 50W 100V LINE
 IP65**

Technical Specifications

	SP219	SP319	SP220	HS725	HS750
Power rating	10W 100V		20W 100V	30W 100V line	50W 100V line
Power tapping (100V Line)	Fixed at 10W		7.5 / 15 / 20W	30 / 15 / 7.5 / 3.8W	50 / 25 / 12.5W
Speaker	5"	2 x 5"	5"	5" (125mm)	5"
Primary impedance (Ohm)	1 K		1.3 / 0.67 / 0.5K	333 / 667 / 1.3 K / 2.6 K	200 / 400 / 800
Secondary impedance (Ohm)	8				
Frequency response @ 1 KHz +/- 3dB	130 - 15 KHz		90 - 15KHz	100 - 10 KHz	90 - 17 KHz
SPL (1W / m @ 1 KHz)	91 dB		90 dB	90 dB	98 dB
Grille / enclosure	Mild Steel / Aluminum		Mildsteel / ABS	Aluminum / ABS	ABS
Overall size (WxHxD) mm	138 (D) x 205 (H)		140 (D) x 195 (H)	366 x 172 x 272	363 x 253 x 310
Weight	2 kg	3 kg	1.2 kg	3.55 kg	4 kg
Colour	White			Light grey	Beige



HS815 & HS830 : HORN SPEAKER WITH ROUND FLARE

Both models are constructed using rounded aluminum flare of 8" (HS815) and 12" (HS830) with multiple power selection via rotary switch. Suitable for schools, mosques, car parks, factories at indoor or under shade installations and that requires omni direction sound broadcast.

Packing information

HS815 : 695 (W) x 480 (H) x 520 (D) mm
: 23 kg
: 12 uts per carton

HS830 : 665 (W) x 665 (H) x 355 (D) mm
: 10.6 kg
: 4 uts per carton



HS815 8" 15W 100V LINE
IP65



HS830 12" 30W 100V LINE
IP65



HS880 20" 80W 100V LINE
IP65

HS880 : HIGH POWER HORN SPEAKER

Constructed using rounded aluminum flare of 20" (HS880) with multiple power selection. It is suitable for schools, mosques, fencing perimeters etc, which requires loud and clear broadcast.

Packing information

HS880 : 585 (W) x 390 (H) x 560 (D) mm
: 6.2 kg
: 1 unit per carton

HS820 & HS822 : HORN SPEAKER WITH RECT. FLARE

Constructed with high impact ABS flares rectangular shape to suit installation sites where pattern of broadcast shall be controlled, such as low level car parks, corridors, etc. Suitable for indoor or outdoor sites with IP65 rating.

Packing information

HS820 : 480 (W) x 365 (H) x 510 (D) mm
: 14.2 kg
: 8 uts per carton



HS820 6" X 8" 15W 100V LINE
IP65



HS822 30W 100V LINE
IP65

Technical Specifications

	HS815	HS830	HS880	HS820	HS822
Power rating	15W 100V	30W 100V	80W 100V	15W 100V	30W 100V
Power tapping (W)	1 / 3 / 5 / 10 / 15	3 / 5 / 10 / 15 / 30	20 / 40 / 60 / 80	1.9 / 3.8 / 7.5 / 15	3.8 / 7.5 / 15 / 30
Primary Impedance (Ohm)	670 1 K 2 K 3.3 K 10 K	330 670 1 K 2 K 3.3 K	125 160 250 500 -	667 1.33K 2.63K 5.26K -	330 670 1.33 2.63
Secondary impedance (Ohm)	8		16	8	
Frequency response @ 1KHz +/- 3dB	350 ~ 7 KHz	300 ~ 10 KHz	160 ~ 6 KHz	250 ~ 8 KHz	400 - 8 KHz
SPL (1W / m @ 1 KHz)	103 dB	105 dB	110 dB	105 dB	105 dB
Flare material	Aluminum			ABS	ABS
Flare dimension	8" round	12" round	20" round	160 x 220 mm	285 x 205 mm
Driver enclosure	ABS		Aluminum Diecast	ABS	
Overall size (dia x height) mm	210 x 240	310 x 325	504 x 335	222(W) x 162(H) x 232(D)	293(W) x 212(H) x 290(D)
Weight	1.55 kg	1.85 kg	3.35 kg	1.7 kg	1.75 kg
Colour	Beige			White	

Back Enclosures



Optional back enclosures with 60mm depth for volume controllers / patch panels.

EC7012 : 70 X 120 mm conceal (steel)

ES7012 : 70 x 120 mm surface mounting (steel)

EA9090 : 86 x 86 mm concealed mounting (ABS)

ES9090 : 86 x 86 mm surface (steel)

Rack Panels

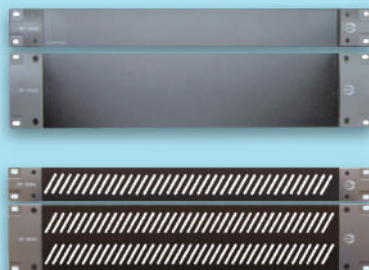

Amperes harmonious mounting ears blank and vent panels with black powder epoxy coating.

BP1000 : 1 hu blank panel

BP2000 : 2 hu blank panel

VP1000 : 1 hu ventilation panel

VP2000 : 2 hu ventilation panel

Patch Panels

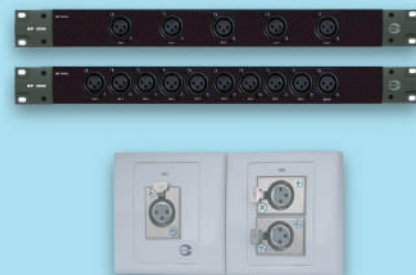

XLR patch panel for rack and wall mount.

MR5000 : 5 Way rack mount female XLR

MR1000 : 10 Way rack mount female XLR

MP1000 : Single inlet female XLR panel

MP2000 : Double inlet female XLR panel

SLA Batteries



SLA battery bank for back up supply. Recommended battery charger is Amperes BC9740.

DAEWOO 12 - 26: 26 Ah

DAEWOO 12 - 40: 40 Ah

DAEWOO 12 - 65: 65 Ah

DAEWOO 12 - 100 : 100 Ah

Power Supply

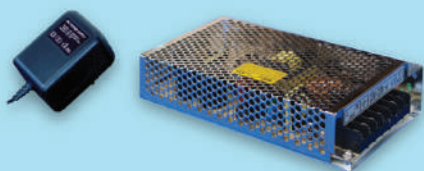

Regulated power adaptor / switching PSU for powering loose equipment.

PS1205 : 12V 0.5A AC / DC adaptor

PS2405 : 24V 0.5A AC / DC adaptor

PS9000 : 24V 4.5A DC switching power module

Surge Arrestor



Suitable for surge protection of external speaker installations. Protects horn speakers against harmful surge.

HP 175VL : 175V peak surge arrester

Fiber Optic Converter



Single mode / multi mode RJ45 - Fiber converter for IP paging application.

HTB110 : Multimode with SC/ST connectors

HTB110S : Single mode with SC connectors

CALCULATING BACK UP BATTERY CAPACITY



For most commercial installations, it is a requirement by local authority that the PA system must be able to operate during power failure. The means for back up supply to the system can be from building's standby generator or via standalone back up power supply bank ie. Batteries.

Batteries can be NiCd or usually SLA type. Steps below provide a simple calculation method on the capacity of batteries required (24V).

Step 1 : Sum up total current drawn in the system and operating period required using back up batteries.

ie. Total current drawn under 24V supply is 30A and 2 hrs of full load operation is required

$$\text{Capacity C1 : } 30 \times 2 = 60 \text{ Ah}$$

Step 2 : Residual voltage percentage to remain at batteries to avoid total discharge, which may cause permanent damage to the cells. (Refer to manufacturer's data for safe value)

ie. 30% Voltage to remain

$$\text{Capacity C2 : } 60 / 0.7 = 85.7 \text{ Ah}$$

Step 3 : Determine optimum discharge rate. Discharge rate differs according to the battery capacity. (Refer to manufacturer's data)

ie. If it is recommended to draw 5 amp / hour from a battery

$$\text{Capacity C3 : } 85.7 / 0.5 = 171.4 \text{ Ah}$$

Step 4 : Duty cycle may differ according to type of load. Music broadcast has lower duty cycle as compared to siren. Using a factor of 20% for music,

ie. 20% of current shall be drawn in an hour ie. duty cycle = 20%

$$\text{BATTERY CAPACITY REQUIRED : } 171.4 \times 0.2 = 34.28 \text{ Ah}$$

Thereby the nearest standard capacity available is 40 Ah, which would be used for the system.

A calculation table is available in Technical Section of www.ampereselectronics.com

SOURCE OF INFO : VARIOUS

CORRECT WAY OF POWERING EQUIPMENT WITH 24V DC



It is a misinformed idea to save some equipment cost in powering up equipment with 24V DC by using voltage output from battery charger instead of a 24V DC power supply unit or adaptor. It shall damage the equipment concerned as normally they can operate in the range of 10% voltage tolerance and anything above that shall stress the power regulating circuitries. Not only it would shorten the life span but excessive heat would be generated.

Voltage from battery charger is normally around 27 to 28V DC whereas from power supply unit ie. Amperes PS9400 is regulated at 24V DC. Thereby it is highly recommended to use suitable regulated power supply unit for operation.

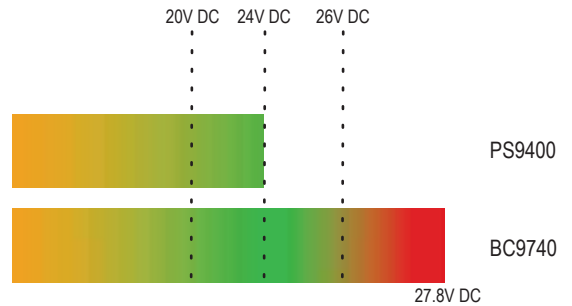

The chart shows typical voltage output from a 24V DC regulated power supply against 24V DC battery charger. Most equipment can operate in the voltage range indicated by green colour. Apparently, it is not advisable to use battery charger's output as operating power source.

First Digit (Protection fr. Solid Object)		Second Digit (Protection from liquid)	
0	No Protection	0	No Protection
1	Solid object of up to 50 mm and above	1	Vertically falling water drops
2	Solid object of up to 12 mm and above	2	Water spray with 15° vertical angle
3	Solid object of up to 2.5 mm and above	3	Water spray with 60° vertical angle
4	Solid object of up to 1 mm and above	4	Water spray with full all direction with allowance
5	Dust with no harmful deposits	5	Low pressure water jet from all direction
6	Full protection from dust	6	High pressure water jet from all direction
		7	Temporary immersion in water
		8	Long immersion in water

SOURCE OF INFO : VARIOUS

IP RATINGS



Ingress Protection up is a classification to indicate the degree of protection of enclosures (such as speakers) against penetration of solid particles and moisture.

It is usually stated in two digits, IP54, which the first digit refers to protection against solid object and the second digit for protection from moisture.

Ref Standards : IEC 60529

VOICE ALARM SYSTEM; CODE OF PRACTICE

The following standards are applicable in design of PA system for commercial applications;

- BS 5839 Part 8 : 2013 : Code of practice for the design, installation, commissioning and maintenance of voice alarm system
- EN 54 Part 16 : Design of Voice Alarm Control and Indicating Equipment
- EN 54 Part 24 : Requirements for the design and construction of loudspeakers
- SS 546: 2009 : Emergency voice communication system in building (Singapore Standards)

The use of the above documents : “As a code of practice, this standard takes the form of guidance and recommendations. It should not be quoted as if it were a specification and particular care should be taken to ensure that claims of compliance are not misleading. “

NEED FOR A VAS

It is proven that most people react in a timely manner to voice messages as compared to bells / sounders or text information. A voice message reduces wastage of precious time during distress in advising occupants to react to an emergency.

The followings are extracts from BS5839 Part 8 : 2013, Summarised points and applicable products from Amperes that shall be able to comply with the clause stated. This guide does not attempt to cover all the details of the standards and the best reading of the requirements is through the publication itself.



Scope	Brief	Applicable component from Amperes
Type of VAS	Types of systems categorized as :- Type V1 : Automatic evacuation Type V2 : Live emergency messages Type V3 : Zonal live emergency messages Type V4 : Manual controls Type V5 : Engineered systems (tailored solution)	Various components are available from Amperes to cater for the different types of VAS
Design of system	Type of system, zoning and circuit based on type requirement of the said building	EP1200 FI6000
Fire Alarm System and VAS Link	The necessary link between the two systems and their communication path	
Fault monitoring	Fault reporting of system components and transmission paths ie. Speaker circuits, battery level, power supply and emergency microphone	LS4600 BC9740
Loudspeaker zones	Design of loudspeaker zones, such as emergency zones, BGM and paging.	Configuration using ZS Series of zone selectors
Speaker types	Speaker types, quantity, location and orientation based on acoustic environment, ambient noise level, coverage area, mounting type, etc	Various types of speakers are available for different needs and applications
Power amplifiers	Amplifier selection with good frequency response, load design and provision for standby amplifier, with amplifier changeover unit	QP and PA Series amplifiers AX3800 / AC3801
Ambient noise sensing	Application of noise sensor to provide a comfortable listening intelligibility	AV7200
Emergency microphone	States the requirement for emergency microphone; frequency response, low distortion, priority, location and operating method.	EP1200

Scope	Brief	Applicable component from Amperes
Emergency messages generator	Specifies the requirement of audio message quality and playback device and recording media.	MR1301
Emergency messages	Importance of the delivery of voice message either live or pre-recorded announcements ; - quality, sequence and language of communication	Sample messages are available upon request
Priorities of messages	Order of messages in accordance to priority level ; - emergency microphone - pre-recorded evacuate message - pre-recorded alert message - other pre-recorded message - non emergency message	Messages are prioritised as required such as Paging over BGM, EP over Paging, etc
Placement of VACIE	This clause is about the placement of the equipment in appropriate location and facilities / indications provided	
Power supplies	It concerns the power supply to VAS, its back up during mains failure and isolation of power sources, indications and back up battery bank capacity and its charging time	BC9740

Other parts of the standards include the followings:

- Cabling of speaker circuit and its safety requirement
- Electrical safety precautions to VAS equipment
- Responsibility of installer, practices and workmanship
- Inspection and testing of wiring
- Commissioning and handover procedures including documentation and certification
- Acceptance and verification of installed system
- Maintenance of the system including user responsibility

RECOMMENDED MESSAGE SEQUENCE

Broadcast of Alert or Evacuate message should follow the sequence as shown below. The type of message can be customised to suit local environment such as language differences. In some cases it can be coded which is to alert staffs on possible emergency cases to avoid panic to the public.

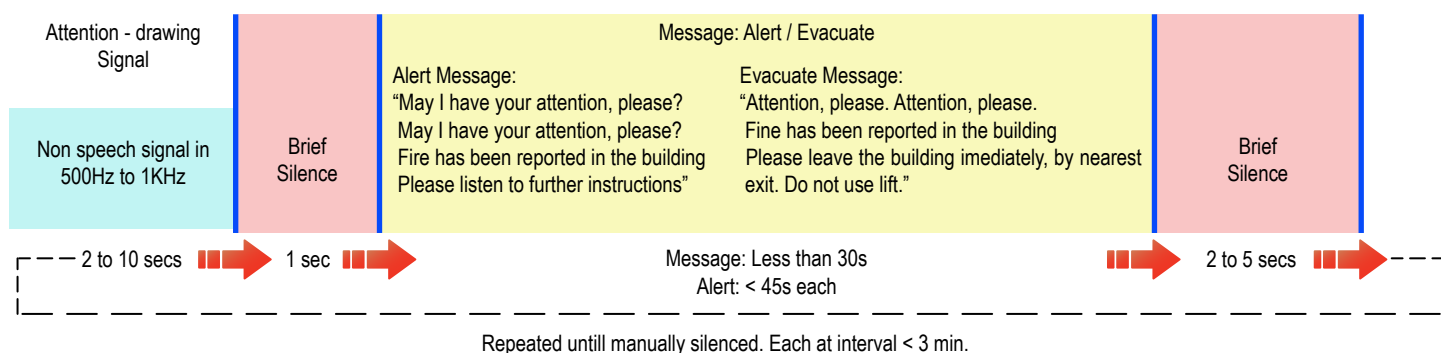

SOURCE: BSI PUBLICATION

CHOOSE THE RIGHT INSTALLER



It is important that competent and well trained personnel are consulted and engaged in the design process, installation, testing and commissioning of the system to avoid design errors resulting in less than expected system worthiness.

Please consult us for details.

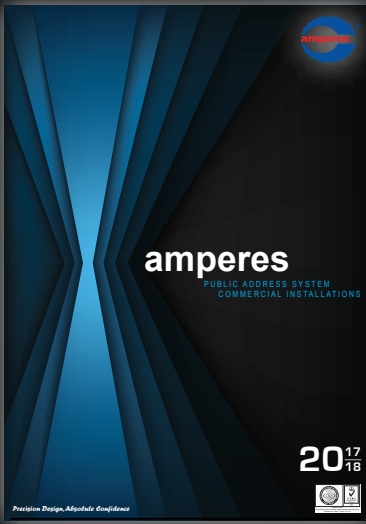

Due to our continuous product improvement policy, amperes electronics reserves the rights to change the specifications, features and artwork without prior notifications.

While every care had been taken to ensure the information contained in this catalogue is correct at the time of printing, some minor errors may be unintentionally inserted. Kindly contact us for clarifications should any doubt arises. Amperes shall be indemnified against any claims caused by any errors in the printing.

The "amperes" logo is a registered trademark of **Amperes Electronics Sdn Bhd (Co No:509025-X)** Malaysia.

Copyrights Reserved @2017



www.ampereselectronics.com

Related materials such as engineer's specifications, instruction manuals, product drawings and catalogue in softcopy are available in CD-ROM and website.

Models which are not available in this version of catalogue are considered discontinued from production or latest products which are yet launched at the time of printing.

Kindly contact your nearest distributor or e-mail to us for further information.

Distributed By :